

**MODEL:  
PCISA-BT**

**Half-Size PCISA CPU Card with 22nm Intel® Atom™ or Celeron® SoC, Dual Intel® PCIe GbE, VGA, iDP, PCIe Mini, USB 3.0, mSATA, SATA 3Gb/s, COM, HD Audio and RoHS**

# User Manual

# Revision

---

Date	Version	Changes
June 30, 2017	1.04	Updated BIOS spec on page 8
July 6, 2016	1.03	Marked LVDS function as optional
January 11, 2016	1.02	Changed part number of the optional LPT cable Modified Table 3-15: Internal DisplayPort Connector Pinouts
October 12, 2015	1.01	Updated 1.7 Technical Specifications
August 12, 2015	1.00	Initial release

# Copyright

---

## **COPYRIGHT NOTICE**

The information in this document is subject to change without prior notice in order to improve reliability, design and function and does not represent a commitment on the part of the manufacturer.

In no event will the manufacturer be liable for direct, indirect, special, incidental, or consequential damages arising out of the use or inability to use the product or documentation, even if advised of the possibility of such damages.

This document contains proprietary information protected by copyright. All rights are reserved. No part of this manual may be reproduced by any mechanical, electronic, or other means in any form without prior written permission of the manufacturer.

## **TRADEMARKS**

All registered trademarks and product names mentioned herein are used for identification purposes only and may be trademarks and/or registered trademarks of their respective owners.

# Manual Conventions

---

**WARNING**

Warnings appear where overlooked details may cause damage to the equipment or result in personal injury. Warnings should be taken seriously.

**CAUTION**

Cautionary messages should be heeded to help reduce the chance of losing data or damaging the product.

**NOTE**

These messages inform the reader of essential but non-critical information. These messages should be read carefully as any directions or instructions contained therein can help avoid making mistakes.

**HOT SURFACE**

This symbol indicates a hot surface that should not be touched without taking care.

# Table of Contents

<b>1 INTRODUCTION.....</b>	<b>1</b>
1.1 INTRODUCTION.....	2
1.2 MODEL VARIATIONS .....	2
1.3 FEATURES.....	3
1.4 CONNECTORS .....	4
1.5 DIMENSIONS.....	5
1.6 DATA FLOW .....	6
1.7 TECHNICAL SPECIFICATIONS .....	7
<b>2 PACKING LIST.....</b>	<b>10</b>
2.1 ANTI-STATIC PRECAUTIONS .....	11
2.2 UNPACKING PRECAUTIONS.....	11
2.3 PACKING LIST.....	12
2.4 OPTIONAL ITEMS .....	13
<b>3 CONNECTORS .....</b>	<b>15</b>
3.1 PERIPHERAL INTERFACE CONNECTORS.....	16
3.1.1 PCISA-BT Layout.....	16
3.1.2 Peripheral Interface Connectors .....	17
3.1.3 External Interface Panel Connectors.....	18
3.2 INTERNAL PERIPHERAL CONNECTORS .....	18
3.2.1 ATX Power Supply Enabled Connector .....	18
3.2.2 Audio Connector .....	19
3.2.3 Backlight Inverter Connector (Optional).....	20
3.2.4 Battery Connector.....	21
3.2.5 Digital I/O Connector .....	22
3.2.6 EC Debug Connector.....	23
3.2.7 Fan Connector (CPU).....	24
3.2.8 Fan Connectors (System).....	25
3.2.9 Front Panel Connector .....	25



3.2.10 PC Connector .....	26
3.2.11 Infrared Interface Connector .....	27
3.2.12 Internal DisplayPort Connector .....	28
3.2.13 Keyboard and Mouse Connector .....	29
3.2.14 LVDS Connector (Optional) .....	30
3.2.15 microSD Card Slot .....	31
3.2.16 mSATA Slot.....	31
3.2.17 Parallel Port Connector .....	33
3.2.18 PCIe Mini Slot.....	34
3.2.19 Power Button .....	35
3.2.20 Reset Button .....	36
3.2.21 SATA 3Gb/s Drive Connector .....	37
3.2.22 Serial Port Connector, RS-232.....	38
3.2.23 Serial Port Connector, RS-422/485.....	38
3.2.24 SMBus Connector .....	39
3.2.25 SO-DIMM Slot .....	40
3.2.26 SPI Flash Connector.....	41
3.2.27 SPI Flash Connector, EC .....	41
3.2.28 TPM Connector.....	42
3.2.29 USB 2.0 Connector (Type A).....	43
3.2.30 USB 2.0 Connectors.....	44
<b>3.3 EXTERNAL PERIPHERAL INTERFACE CONNECTOR PANEL .....</b>	<b>45</b>
3.3.1 Ethernet Connectors .....	45
3.3.2 USB 2.0 Connector .....	46
3.3.3 USB 3.0 Connector .....	46
3.3.4 VGA Connector.....	47
<b>4 INSTALLATION .....</b>	<b>48</b>
4.1 ANTI-STATIC PRECAUTIONS .....	49
4.2 INSTALLATION CONSIDERATIONS.....	49
4.3 SO-DIMM INSTALLATION .....	51
4.4 FULL-SIZE PCIe MINI CARD INSTALLATION .....	51
4.5 HALF-SIZE PCIe MINI CARD INSTALLATION.....	53
4.6 mSATA MODULE INSTALLATION .....	56
4.7 SYSTEM CONFIGURATION.....	58

## PCISA-BT CPU Card

4.7.1 AT/ATX Power Mode Setting .....	58
4.7.2 Clear CMOS Button.....	58
4.7.3 LVDS Panel Type Selection (Optional).....	59
4.7.4 LVDS Backlight Mode Selection (Optional) .....	60
4.7.5 LVDS Voltage Selection (Optional).....	61
4.8 INTERNAL PERIPHERAL DEVICE CONNECTIONS.....	62
4.8.1 SATA Drive Connection .....	62
<b>5 BIOS.....</b>	<b>64</b>
5.1 INTRODUCTION.....	65
5.1.1 Starting Setup.....	65
5.1.2 Using Setup .....	65
5.1.3 Getting Help.....	66
5.1.4 Unable to Reboot after Configuration Changes .....	66
5.1.5 BIOS Menu Bar.....	66
5.2 MAIN.....	67
5.3 ADVANCED .....	68
5.3.1 ACPI Settings .....	69
5.3.2 F81866 Super IO Configuration .....	70
5.3.2.1 Serial Port n Configuration .....	70
5.3.2.2 IrDA Configuration.....	76
5.3.2.3 Parallel Port Configuration .....	78
5.3.3 iWDD H/W Monitor.....	80
5.3.3.1 Smart Fan Mode Configuration .....	81
5.3.4 RTC Wake Settings .....	82
5.3.5 Serial Port Console Redirection .....	83
5.3.6 iEi Feature .....	86
5.3.7 CPU Configuration .....	87
5.3.8 IDE Configuration.....	88
5.3.9 Trusted Computing .....	89
5.3.10 USB Configuration.....	90
5.4 CHIPSET .....	91
5.4.1 North Bridge .....	92
5.4.1.1 Intel IGD Configuration.....	92
5.4.2 South Bridge.....	94

5.4.2.1 PCI Express Configuration .....	95
5.5 SECURITY .....	96
5.6 BOOT .....	97
5.7 SAVE & EXIT .....	99
<b>6 SOFTWARE DRIVERS .....</b>	<b>100</b>
6.1 SOFTWARE INSTALLATION .....	101
6.2 AVAILABLE SOFTWARE DRIVERS .....	102
<b>A REGULATORY COMPLIANCE .....</b>	<b>104</b>
<b>B PRODUCT DISPOSAL .....</b>	<b>106</b>
<b>C BIOS OPTIONS .....</b>	<b>108</b>
<b>D TERMINOLOGY .....</b>	<b>111</b>
<b>E DIGITAL I/O INTERFACE .....</b>	<b>115</b>
E.1 INTRODUCTION .....	116
E.2 ASSEMBLY LANGUAGE SAMPLE 1 .....	117
E.3 ASSEMBLY LANGUAGE SAMPLE 2 .....	117
<b>F WATCHDOG TIMER .....</b>	<b>118</b>
<b>G HAZARDOUS MATERIALS DISCLOSURE .....</b>	<b>121</b>



# List of Figures

Figure 1-1: PCISA-BT .....	2
Figure 1-2: Connectors .....	4
Figure 1-3: PCISA-BT Dimensions (mm).....	5
Figure 1-4: Data Flow Diagram.....	6
Figure 3-1: Peripheral Interface Connectors .....	16
Figure 3-2: ATX Power Supply Enabled Connector Location.....	19
Figure 3-3: Audio Connector Location.....	20
Figure 3-4: Backlight Inverter Connector Location.....	21
Figure 3-5: Battery Connector Location.....	22
Figure 3-6: Digital I/O Connector Location .....	22
Figure 3-7: EC Debug Connector Location.....	23
Figure 3-8: CPU Fan Connector Location .....	24
Figure 3-9: System Fan Connector Locations.....	25
Figure 3-10: Front Panel Connector Location .....	26
Figure 3-11: I <sup>2</sup> C Connector Location .....	27
Figure 3-12: Infrared Connector Location.....	27
Figure 3-13: Internal DisplayPort Connector Location.....	28
Figure 3-14: Keyboard and Mouse Connector Location.....	29
Figure 3-15: LVDS Connector Location.....	30
Figure 3-16: microSD Card Slot Location .....	31
Figure 3-17: mSATA Slot Location .....	32
Figure 3-18: Parallel Port Connector Location.....	33
Figure 3-19: PCIe Mini Slot Location .....	34
Figure 3-20: Power Button Location.....	36
Figure 3-21: Reset Button Location.....	36
Figure 3-22: SATA 3Gb/s Drive Connector Locations .....	37
Figure 3-23: RS-232 Serial Port Connector Locations.....	38
Figure 3-24: RS-422/485 Connector Location.....	39
Figure 3-25: SMBus Connector Location.....	40
Figure 3-26: SO-DIMM Slot Location .....	40

Figure 3-27: SPI Flash Connector Location.....	41
Figure 3-28: SPI EC Flash Connector Location.....	42
Figure 3-29: TPM Connector Location.....	42
Figure 3-30: USB 2.0 Connector (Type A) Pinout Location.....	43
Figure 3-31: USB 2.0 Connector Pinout Locations .....	44
Figure 3-32: External Peripheral Interface Connector .....	45
Figure 3-33: Ethernet Connector.....	45
Figure 3-34: VGA Connector .....	47
Figure 4-1: SO-DIMM Installation .....	51
Figure 4-2: Removing the Retention Screw .....	52
Figure 4-3: Inserting the Full-size PCIe Mini Card into the Slot at an Angle .....	52
Figure 4-4: Securing the Full-size PCIe Mini Card .....	53
Figure 4-5: Removing the Standoff.....	54
Figure 4-6: Installing the Standoff .....	54
Figure 4-7: Inserting the Half-size PCIe Mini Card into the Slot at an Angle.....	55
Figure 4-8: Securing the Half-size PCIe Mini Card .....	55
Figure 4-9: Removing the Retention Screws for the mSATA Module.....	56
Figure 4-10: Inserting the mSATA Module into the Socket at an Angle .....	57
Figure 4-11: Securing the mSATA Module.....	57
Figure 4-12: AT/ATX Power Mode Switch Location .....	58
Figure 4-13: Clear CMOS Button Location.....	58
Figure 4-14: LVDS Panel Type Selection Switch Location.....	60
Figure 4-15: LVDS Backlight Mode Selection Jumper Location.....	60
Figure 4-16: LVDS Voltage Selection Jumper Location .....	61
Figure 4-17: SATA Drive Cable Connection.....	62
Figure 4-18: SATA Power Drive Connection.....	63
Figure 6-1: Introduction Screen .....	101
Figure 6-2: Available Drivers .....	102

# List of Tables

---

Table 1-1: Model Variations .....	2
Table 1-2: PCISA-BT Specifications .....	9
Table 2-1: Packing List.....	12
Table 2-2: Optional Items.....	14
Table 3-1: Peripheral Interface Connectors .....	18
Table 3-2: External Peripheral Connectors .....	18
Table 3-3: ATX Power Supply Enabled Connector Pinouts .....	19
Table 3-4: AT/ATX Power Mode Setting .....	19
Table 3-5: Audio Connector Pinouts .....	20
Table 3-6: Backlight Inverter Connector Pinouts .....	21
Table 3-7: Battery Connector Pinouts .....	22
Table 3-8: Digital I/O Connector Pinouts.....	23
Table 3-9: EC Debug Connector Pinouts .....	24
Table 3-10: CPU Fan Connector Pinouts .....	24
Table 3-11: System Fan Connector Pinouts .....	25
Table 3-12: Front Panel Connector Pinouts.....	26
Table 3-13: I <sup>2</sup> C Connector Pinouts.....	27
Table 3-14: Infrared Connector Pinouts .....	28
Table 3-15: Internal DisplayPort Connector Pinouts .....	29
Table 3-16: Keyboard and Mouse Connector Pinouts.....	30
Table 3-17: LVDS Connector Pinouts.....	31
Table 3-18: mSATA Slot Pinouts.....	33
Table 3-19: Parallel Port Connector Pinouts .....	34
Table 3-20: PCIe Mini Slot Pinouts.....	35
Table 3-21: SATA 3Gb/s Drive Connector Pinouts.....	37
Table 3-22: RS-232 Serial Port Connector Pinouts .....	38
Table 3-23: RS-422/485 Connector Pinouts .....	39
Table 3-24: DB-9 RS-422/485 Pinouts .....	39
Table 3-25: SMBus Connector Pinouts .....	40
Table 3-26: SPI Flash Connector Pinouts .....	41

<b>Table 3-27: SPI EC Flash Connector Pinouts .....</b>	<b>42</b>
<b>Table 3-28: TPM Connector Pinouts .....</b>	<b>43</b>
<b>Table 3-29: USB 2.0 Connector (Type A) Pinouts .....</b>	<b>44</b>
<b>Table 3-30: USB 2.0 Connector Pinouts .....</b>	<b>44</b>
<b>Table 3-31: LAN Pinouts .....</b>	<b>45</b>
<b>Table 3-32: USB 2.0 Port Pinouts .....</b>	<b>46</b>
<b>Table 3-33: USB 3.0 Port Pinouts .....</b>	<b>46</b>
<b>Table 3-34: VGA Connector Pinouts .....</b>	<b>47</b>
<b>Table 4-1: AT/ATX Power Mode Switch Settings .....</b>	<b>58</b>
<b>Table 4-2: LVDS Panel Type Selection .....</b>	<b>59</b>
<b>Table 4-3: LVDS Backlight Mode Selection Jumper Settings .....</b>	<b>60</b>
<b>Table 4-4: LVDS Voltage Selection Jumper Settings .....</b>	<b>61</b>
<b>Table 5-1: BIOS Navigation Keys .....</b>	<b>66</b>

# BIOS Menus

---

BIOS Menu 1: Main .....	67
BIOS Menu 2: Advanced .....	68
BIOS Menu 3: ACPI Configuration .....	69
BIOS Menu 4: F81866 Super IO Configuration .....	70
BIOS Menu 5: Serial Port n Configuration Menu .....	70
BIOS Menu 6: IrDA Configuration Menu.....	76
BIOS Menu 7: Parallel Port Configuration Menu .....	78
BIOS Menu 8: iWDD H/W Monitor .....	80
BIOS Menu 9: Smart Fan Mode Configuration .....	81
BIOS Menu 10: RTC Wake Settings .....	82
BIOS Menu 11: Serial Port Console Redirection .....	83
BIOS Menu 12: iEi Feature .....	86
BIOS Menu 13: CPU Configuration .....	87
BIOS Menu 14: IDE Configuration .....	88
BIOS Menu 15: Trusted Computing .....	89
BIOS Menu 16: USB Configuration .....	90
BIOS Menu 17: Chipset .....	91
BIOS Menu 18: North Bridge .....	92
BIOS Menu 19: Intel IGD Configuration.....	92
BIOS Menu 20: South Bridge.....	94
BIOS Menu 21: PCI Express Configuration .....	95
BIOS Menu 22: Security .....	96
BIOS Menu 23: Boot .....	97
BIOS Menu 24: Save & Exit.....	99



Chapter

1

# Introduction

---

## 1.1 Introduction

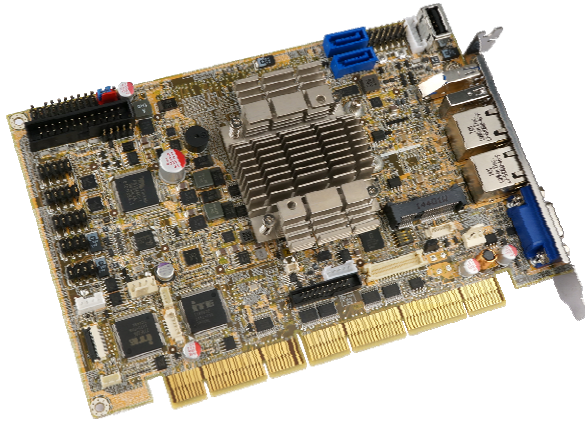

Figure 1-1: PCISA-BT

The PCISA-BT half-size PCISA CPU card is a 22nm Intel® Atom™ or Celeron® SoC platform with a DDR3L SO-DIMM socket and dual PCI Express (PCIe) Gigabit Ethernet (GbE). The PCISA-BT equips with one USB 3.0, six USB 2.0, two SATA 3Gb/s, two RS-232, one RS-422/485, one PCIe Mini slot, one mSATA slot and one microSD slot, providing extreme expansion possibility. Moreover, multiple display support (VGA, iDP and optional LVDS) adds versatility to the system, enabling system integrators and designers increased flexibility in selecting display panel options.

## 1.2 Model Variations

The model variations for the PCISA-BT series are listed in **Table 1-1**.

Model	On-board SoC				
	Name	Clock Speed	# of Cores	L2 Cache	Max TDP
PCISA-BT-E38451	Intel® Atom™ E3845	1.91 GHz	4	2 MB	10 W
PCISA -BT-E38251	Intel® Atom™ E3825	1.33 GHz	2	1 MB	6 W

Table 1-1: Model Variations



### NOTE:

Models with other CPUs not listed in above table are requested by MOQ – 100 pcs/lot.

## PCISA-BT CPU Card

### 1.3 Features

Some of the PCISA-BT motherboard features are listed below:

- Half-size PCISA CPU card
- On-board 22nm Intel® Atom™ or Celeron® SoC
- One 204-pin 1333/1066 MHz unbuffered DDR3L SDRAM SO-DIMM slot supports up to 8 GB
- Dual Intel® PCIe GbE
- Dual independent display by VGA, iDP or optional LVDS interfaces
- Complete I/O interfaces, including one USB 3.0, six USB 2.0, two RS-232, one RS-422/485 and two SATA 3Gb/s
- Flexible expansion options, including one PCIe Mini slot, one mSATA slot and one microSD slot
- High Definition Audio
- RoHS compliant

### 1.4 Connectors

The connectors on the PCISA-BT are shown in the figure below.

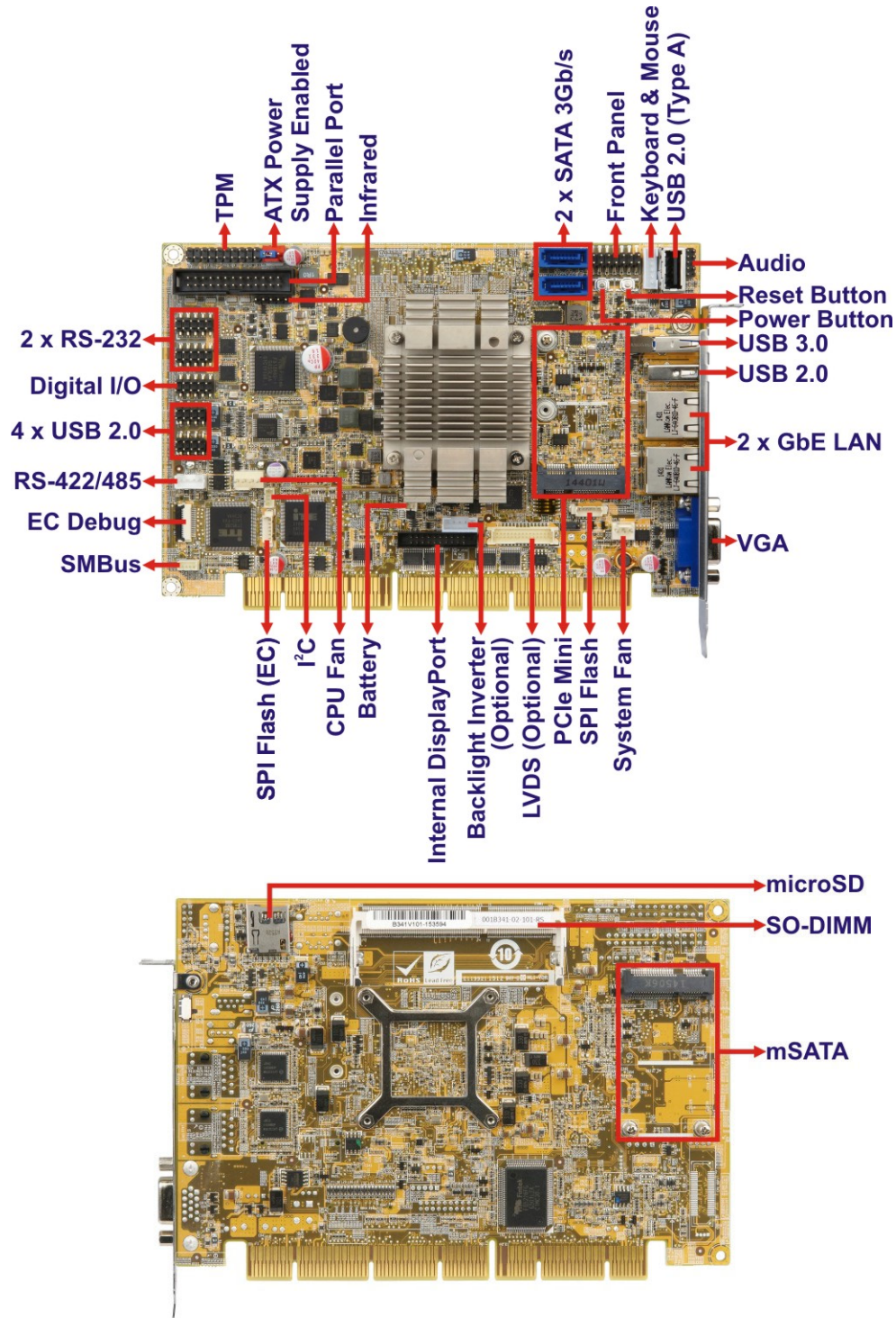

Figure 1-2: Connectors



**PCISA-BT CPU Card**

**1.5 Dimensions**

The main dimensions of the PCISA-BT are shown in the diagram below.

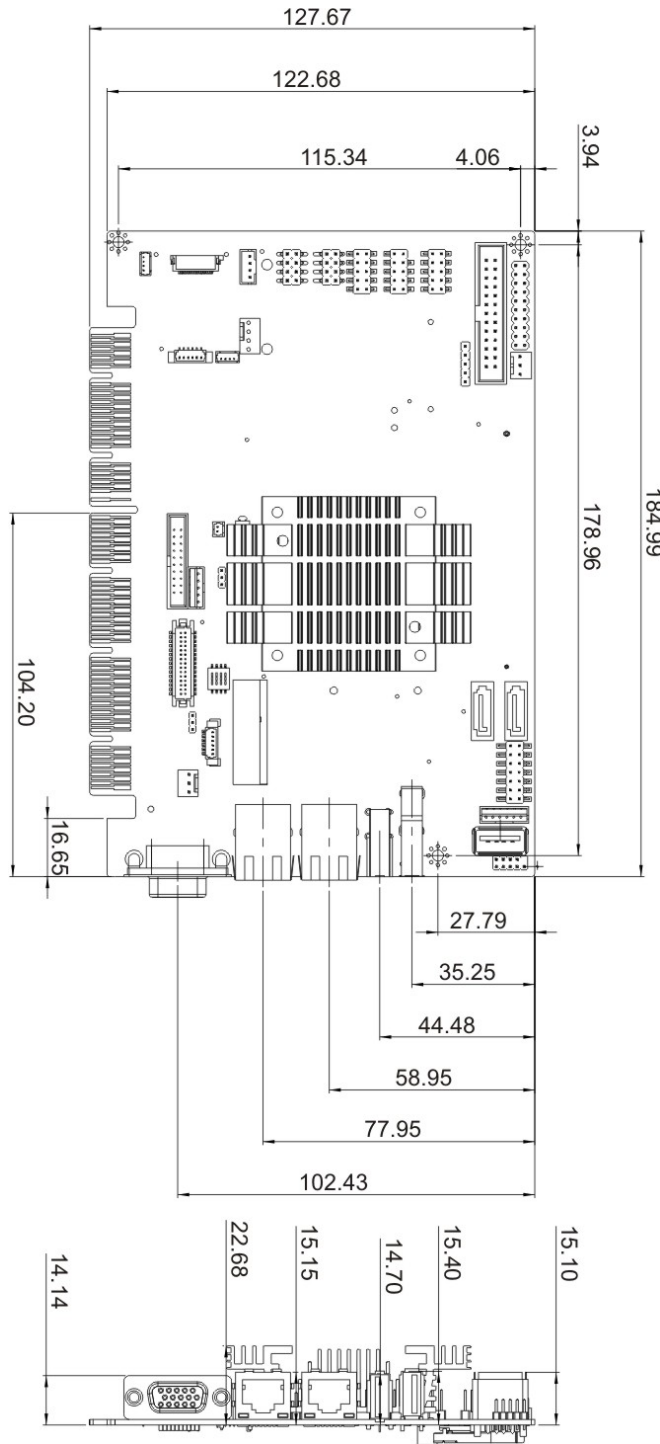

**Figure 1-3: PCISA-BT Dimensions (mm)**



**1.6 Data Flow**

Figure 1-4 shows the data flow between the system chipset, the CPU and other components installed on the motherboard.

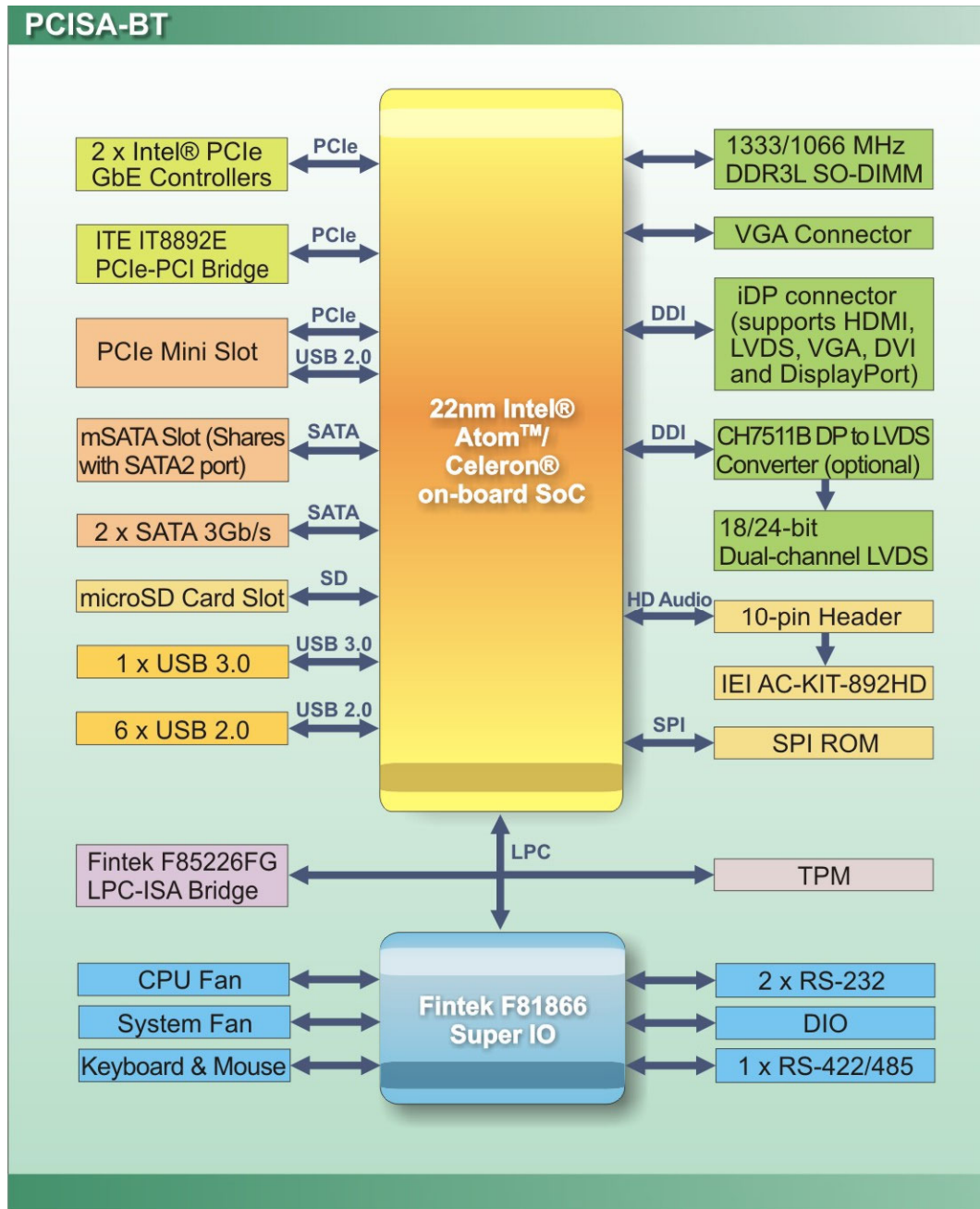

Figure 1-4: Data Flow Diagram

## PCISA-BT CPU Card

### 1.7 Technical Specifications

The PCISA-BT technical specifications are listed below.

Specification/Model	PCISA-BT
<b>Form Factor</b>	Half-size PCISA CPU card
<b>On-board SoC</b>	Intel® Atom™ E3845 (1.91GHz, quad-core, 2MB cache, TDP=10W) Intel® Atom™ E3827 (1.75GHz, dual-core, 1MB cache, TDP=8W) Intel® Atom™ E3826 (1.46GHz, dual-core, 1MB cache, TDP=7W) Intel® Atom™ E3825 (1.33GHz, dual-core, 1MB cache, TDP=6W) Intel® Atom™ E3815 (1.46GHz, single-core, 512KB cache, TDP=5W)
<b>Memory</b>	One 240-pin 1333/1066 MHz unbuffered DDR3L SDRAM SO-DIMM slot supports up to 8 GB
<b>Graphics Engine</b>	Intel® HD Graphics Gen 7 with 4 execution units, supporting DirectX 11.1, OpenCL 1.2 and OpenGL 4.2
<b>Display Output</b>	Supports dual independent display One VGA (up to 2560x1600@60 Hz) One iDP interface for HDMI, LVDS, VGA, DVI and DisplayPort (up to 2560x1600@60 Hz) One 18/24-bit dual-channel LVDS by CH7511B DP to LVDS converter (up to 1920x1200@60 Hz) (optional, MOQ: 100 pcs/lot)
<b>Ethernet</b>	Two Intel® I211-AT PCIe GbE controllers
<b>Audio</b>	Supports 7.1-channel HD audio by IEI AC-KIT-892HD kit One audio connector (10-pin header)
<b>Expansion</b>	One microSD slot One mSATA slot (SATA 3Gb/s, shares with <b>SATA2</b> port) One PCIe Mini slot (full-size/half-size) PCIe-PCI bridge: ITE IT8892E LPC-ISA bridge: Fintek F85226FG PCI and ISA* signal via golden finger  * The ISA function is limited. Please refer to page 9 for details.

<b>Super I/O Controller</b>	Fintek F81866
<b>Watchdog Timer</b>	Software programmable supports 1~255 sec. system reset
<b>BIOS</b>	UEFI BIOS B341A1xx BIOS version is for E38xx SoC B341AMxx BIOS version is for J1900/N2930/N2807 SoC
<b>External I/O Interface Connectors</b>	
<b>Display Output</b>	One VGA connector
<b>Ethernet</b>	Two RJ-45 ports
<b>USB</b>	One USB 3.0 port One USB 2.0 port
<b>Internal I/O Interface Connectors</b>	
<b>Audio Connector</b>	One audio connector (10-pin header)
<b>Digital I/O</b>	8-bit digital I/O
<b>Fan</b>	One 4-pin CPU smart fan connector One 3-pin system smart fan connector
<b>Front Panel</b>	One 14-pin header (power LED, HDD LED, speaker, power button, reset button)
<b>I<sup>2</sup>C</b>	One 4-pin wafer connector
<b>Infrared</b>	One via 5-pin header
<b>Internal DisplayPort</b>	One 20-pin box header
<b>Keyboard and Mouse</b>	One internal keyboard and mouse connector (6-pin wafer)
<b>Parallel Port</b>	One parallel port via internal 26-pin box header
<b>Serial ATA</b>	Two SATA 3Gb/s connectors
<b>Serial Ports</b>	Two RS-232 via internal 10-pin headers One RS-422/485 via internal 4-pin wafer connector
<b>SMBus</b>	One 4-pin wafer connector
<b>TPM</b>	One via 20-pin header

## PCISA-BT CPU Card

<b>USB</b>	Four USB 2.0 ports by two internal pin headers One USB 2.0 port by internal Type A connector
<b>Environmental and Power Specifications</b>	
<b>Power Supply</b>	5V/12V, AT/ATX power support
<b>Power Consumption</b>	5V@1.55A, 12V@0.74A (1.91 GHz Intel® Atom™ E3845 SoC with one 8 GB 1333 MHz DDR3L memory)
<b>Operating Temperature</b>	-20°C ~ 60°C
<b>Storage Temperature</b>	-30°C ~ 70°C
<b>Operating Humidity</b>	5% ~ 95% (non-condensing)
<b>Physical Specifications</b>	
<b>Dimensions</b>	185 mm x 128 mm
<b>Weight (GW/NW)</b>	1000 g/250 g

Table 1-2: PCISA-BT Specifications



### NOTE:

#### ISA Limitation of PCISA-BT

Due to the limitation of Intel® Bay Trail processors, the PCISA-BT does not support the following features:

- Bus Master Cycles
- DMA
- LPC Memory Mapped Transactions
- IRQ0, IRQ1, IRQ2, IRQ8, IRQ9, IRQ13, IRQ14
- ISA Enable (IE) Bit
- PnP

Chapter

**2**

# Packing List

---



## PCISA-BT CPU Card

### 2.1 Anti-static Precautions

---



#### WARNING!

Static electricity can destroy certain electronics. Make sure to follow the ESD precautions to prevent damage to the product, and injury to the user.

---

Make sure to adhere to the following guidelines:

- **Wear an anti-static wristband:** Wearing an anti-static wristband can prevent electrostatic discharge.
- **Self-grounding:** Touch a grounded conductor every few minutes to discharge any excess static buildup.
- **Use an anti-static pad:** When configuring any circuit board, place it on an anti-static mat.
- **Only handle the edges of the PCB:** Don't touch the surface of the motherboard. Hold the motherboard by the edges when handling.

### 2.2 Unpacking Precautions

When the PCISA-BT is unpacked, please do the following:

- Follow the anti-static guidelines above.
- Make sure the packing box is facing upwards when opening.
- Make sure all the packing list items are present.





## 2.3 Packing List

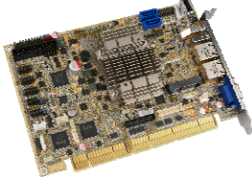

**NOTE:**

If any of the components listed in the checklist below are missing, do not proceed with the installation. Contact the IEI reseller or vendor the PCISA-BT was purchased from or contact an IEI sales representative directly by sending an email to [sales@ieiworld.com](mailto:sales@ieiworld.com).

The PCISA-BT is shipped with the following components:









Quantity	Item and Part Number	Image
1	PCISA-BT CPU card	
1	SATA cable	
1	Utility CD	
1	Quick installation guide	

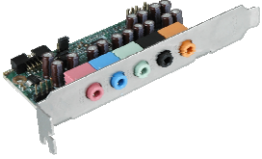
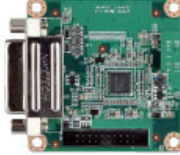

**Table 2-1: Packing List**

## PCISA-BT CPU Card

### 2.4 Optional Items

The following are optional components which may be separately purchased:

Item and Part Number	Image
RS-422/485 cable, 200 mm (P/N: 32205-003800-300-RS)	
Dual RS-232 cable, 230 mm, P=2.54 (P/N: 19800-000051-RS)	
PS/2 KB/MS Y-cable with bracket, 220 mm (P/N: 19800-000075-RS)	
SATA power cable (P/N: 32102-000100-200-RS)	
LPT cable (P/N: 19800-000049-RS)	
7.1-channel HD audio kit with Realtek ALC892 audio codec supporting dual audio stream (P/N: AC-KIT-892HD-R10)	
DisplayPort to HDMI converter board (for IEI iDP connector) (P/N: DP-HDMI-R10)	
DisplayPort to LVDS converter board (for IEI iDP connector) (P/N: DP-LVDS-R10)	
DisplayPort to VGA converter board (for IEI iDP connector) (P/N: DP-VGA-R10)	

Item and Part Number	Image
DisplayPort to DVI-D converter board (for IEI iDP connector) (P/N: DP-DVI-R10)	
DisplayPort to DisplayPort converter board (for IEI iDP connector) (P/N: DP-DP-R10)	
20-pin Infineon TPM module, software management tool, firmware v3.17 (P/N: TPM-IN01-R11)	

**Table 2-2: Optional Items**

Chapter

**3**

# Connectors

---



### 3.1 Peripheral Interface Connectors

This chapter details all the peripheral interface connectors.

#### 3.1.1 PCISA-BT Layout

The figure below shows all the peripheral interface connectors.

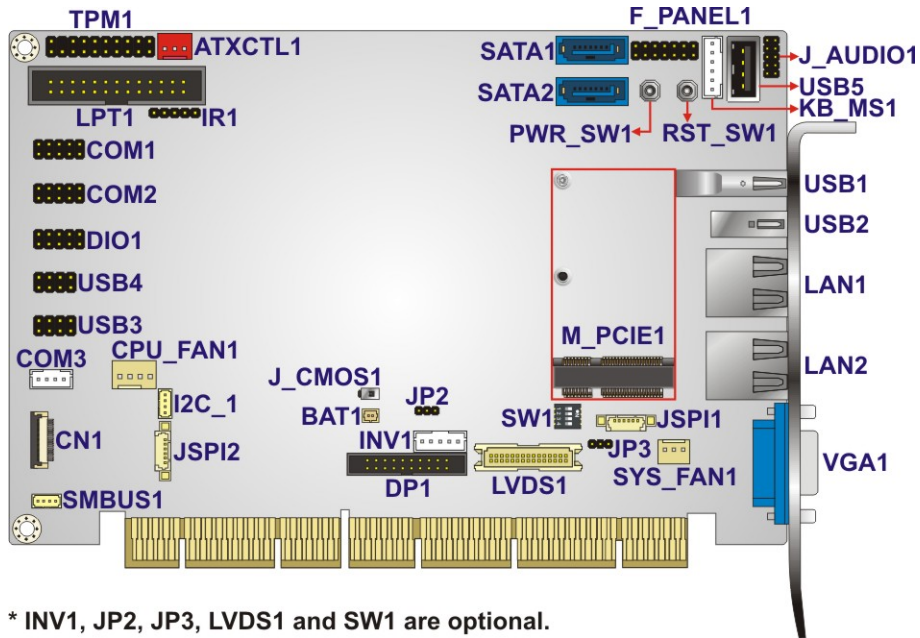

\* INV1, JP2, JP3, LVDS1 and SW1 are optional.

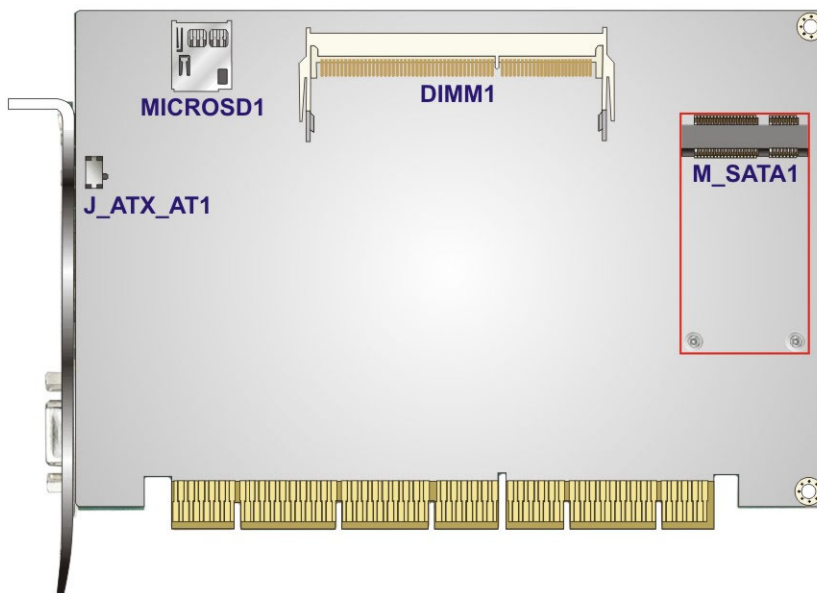

Figure 3-1: Peripheral Interface Connectors

## PCISA-BT CPU Card

### 3.1.2 Peripheral Interface Connectors

The table below lists all the connectors on the board.

Connector	Type	Label
ATX power supply enabled connector	3-pin wafer	ATXCTL1
Audio connector	10-pin header	J_AUDIO1
Backlight inverter connector (optional)	5-pin wafer	INV1
Battery connector	2-pin wafer	BAT1
Digital I/O connector	10-pin header	DIO1
EC debug connector	18-pin header	CN1
Fan connector (CPU)	4-pin wafer	CPU_FAN1
Fan connector (system)	3-pin wafer	SYS_FAN1
Front panel connector	14-pin header	F_PANEL1
I <sup>2</sup> C connector	4-pin wafer	I2C_1
Infrared connector	5-pin header	IR1
Internal DisplayPort connector	20-pin box header	DP1
Keyboard and mouse connector	6-pin wafer	KB_MS1
LVDS connector (optional)	30-pin crimp	LVDS1
microSD slot	microSD slot	MICROSD1
mSATA slot	PCIe Mini slot	M_SATA1
Parallel port connector	26-pin box header	LPT1
PCIe Mini slot	PCIe Mini slot	M_PCIE1
Power button	Push button	PWR_SW1
Reset button	Push button	RST_SW1
SATA 3Gb/s drive connector	7-pin SATA connector	SATA1, SATA2
Serial port, RS-232	10-pin header	COM1, COM2
Serial port, RS-422/485	4-pin wafer	COM3
SMBus connector	4-pin wafer	SMBUS1

Connector	Type	Label
SO-DIMM slot	240-pin DDR3L SO-DIMM slot	DIMM1
SPI flash connector	6-pin wafer	JSPI1
SPI flash connector, EC	6-pin wafer	JSPI2
TPM connector	20-pin header	TPM1
USB 2.0 connector (Type A)	Type A	USB5
USB 2.0 connectors	8-pin header	USB3, USB4

**Table 3-1: Peripheral Interface Connectors**

### 3.1.3 External Interface Panel Connectors

The table below lists the connectors on the external I/O panel.

Connector	Type	Label
Ethernet ports	RJ-45	LAN1, LAN2
USB 2.0 port	USB 2.0	USB2
USB 3.0 port	USB 3.0	USB1
VGA connector	15-pin female	VGA1

**Table 3-2: External Peripheral Connectors**

## 3.2 Internal Peripheral Connectors

The section describes all of the connectors on the PCISA-BT.

### 3.2.1 ATX Power Supply Enabled Connector

- CN Label:** ATXCTL1
- CN Type:** 3-pin wafer, p=2.54 mm
- CN Location:** See **Figure 3-2**
- CN Pinouts:** See **Table 3-3**

## PCISA-BT CPU Card

The ATX power supply enabled connector enables the PCISA-BT to be connected to an ATX power supply. Refer to **Table 3-4** for the configuration of AT/ATX power mode.

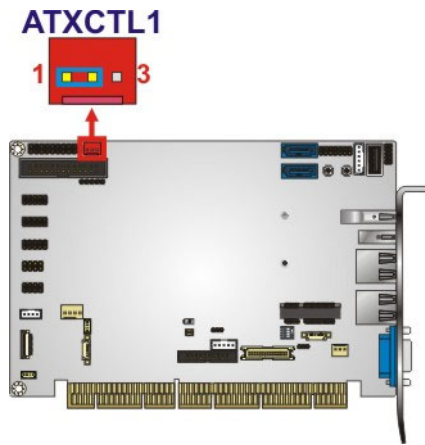

**Figure 3-2: ATX Power Supply Enabled Connector Location**

Pin	Description
1	GND
2	PS_ON#
3	5VSB

**Table 3-3: ATX Power Supply Enabled Connector Pinouts**

The AT/ATX power mode settings are listed below.

Setting	Description
AT Power Mode	Short 1-2 (Default)
ATX Power Mode	Connect PS_ON# and 5VSB cable from ATX power supply

**Table 3-4: AT/ATX Power Mode Setting**

### 3.2.2 Audio Connector

- CN Label:** J\_AUDIO1
- CN Type:** 10-pin header, p=2 mm
- CN Location:** See **Figure 3-3**
- CN Pinouts:** See **Table 3-5**

This connector allows connection to an external audio kit.

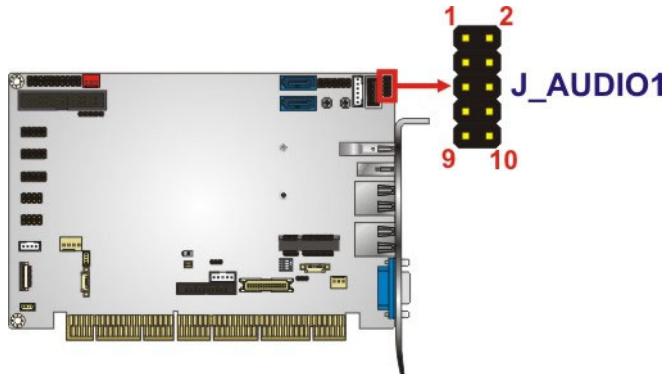

**Figure 3-3: Audio Connector Location**

Pin	Description	Pin	Description
1	HDA_SYNC	2	HDA_BIT_CLK
3	HDA_SDOUT	4	HDA_SPKR
5	HDA_SDIN	6	HDA_RST#
7	HDA_VCC	8	HDA_GND
9	HDA_+12V	10	HDA_GND

**Table 3-5: Audio Connector Pinouts**

### 3.2.3 Backlight Inverter Connector (Optional)

- CN Label:** INV1
- CN Type:** 5-pin wafer, p=2 mm
- CN Location:** See **Figure 3-4**
- CN Pinouts:** See **Table 3-6**

The backlight inverter connector provides power to an LCD panel.



**PCISA-BT CPU Card**

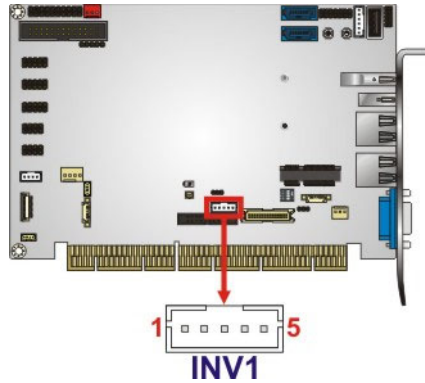

**Figure 3-4: Backlight Inverter Connector Location**

Pin	Description
1	LCD_BKLTCTL
2	GROUND
3	+12V
4	GROUND
5	BACKLIGHT ENABLE

**Table 3-6: Backlight Inverter Connector Pinouts**

**3.2.4 Battery Connector**



**CAUTION:**

Risk of explosion if battery is replaced by an incorrect type. Only certified engineers should replace the on-board battery.

Dispose of used batteries according to instructions and local regulations.

- CN Label:**            **BAT1**
- CN Type:**            2-pin wafer, p=1.25 mm
- CN Location:**      See **Figure 3-5**
- CN Pinouts:**        See **Table 3-7**

This is connected to the system battery. The battery provides power to the system clock to retain the time when power is turned off.

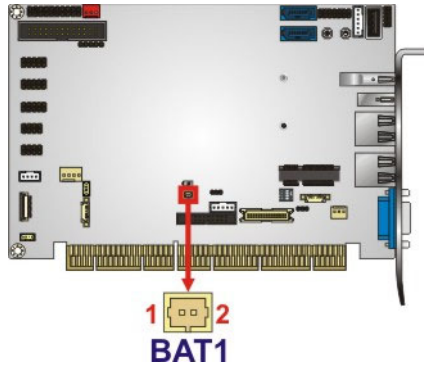

**Figure 3-5: Battery Connector Location**

Pin	Description
1	VBATT
2	GND

**Table 3-7: Battery Connector Pinouts**

### 3.2.5 Digital I/O Connector

- CN Label:** DIO1
- CN Type:** 10-pin header, p=2.54 mm
- CN Location:** See **Figure 3-6**
- CN Pinouts:** See **Table 3-8**

The digital I/O connector provides programmable input and output for external devices.

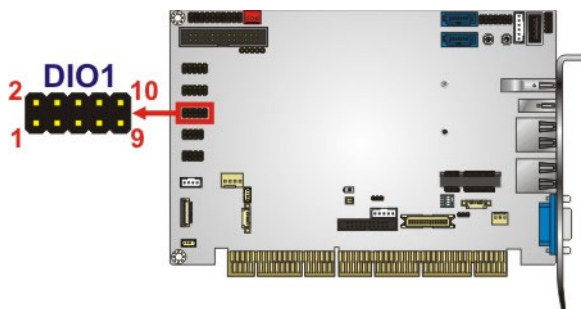

**Figure 3-6: Digital I/O Connector Location**

## PCISA-BT CPU Card

Pin	Description	Pin	Description
1	GND	2	VCC
3	Output 3	4	Output 2
5	Output 1	6	Output 0
7	Input 3	8	Input 2
9	Input 1	10	Input 0

**Table 3-8: Digital I/O Connector Pinouts**

### 3.2.6 EC Debug Connector

- CN Label:** CN1
- CN Type:** 20-pin wafer, p=2 mm
- CN Location:** See **Figure 3-7**
- CN Pinouts:** See **Table 3-9**

The EC debug connector is used for EC debug.

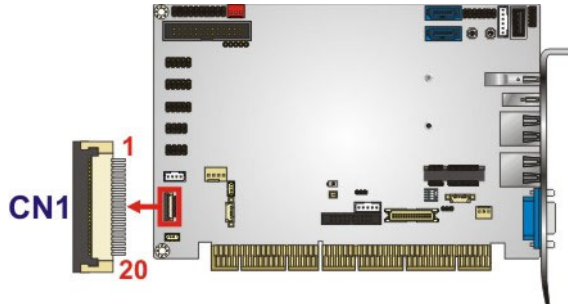

**Figure 3-7: EC Debug Connector Location**

Pin	Description	Pin	Description
1	EC_EPP_STB#	2	EC_EPP_AFD#
3	EC_EPP_PDO	4	NC
5	EC_EPP_PD1	6	EC_EPP_INIT#
7	EC_EPP_PD2	8	EC_EPP_SLIN#
9	EC_EPP_PD3	10	GND
11	EC_EPP_PD4	12	NC
13	EC_EPP_PD5	14	EC_EPP_BUSY

Pin	Description	Pin	Description
15	EC_EPP_PD6	16	EC_EPP_KSI5
17	EC_EPP_PD7	18	EC_EPP_KSI4

**Table 3-9: EC Debug Connector Pinouts**

### 3.2.7 Fan Connector (CPU)

- CN Label:** CPU\_FAN1
- CN Type:** 4-pin wafer, p=2.54 mm
- CN Location:** See **Figure 3-8**
- CN Pinouts:** See **Table 3-10**

The fan connector attaches to a CPU cooling fan.

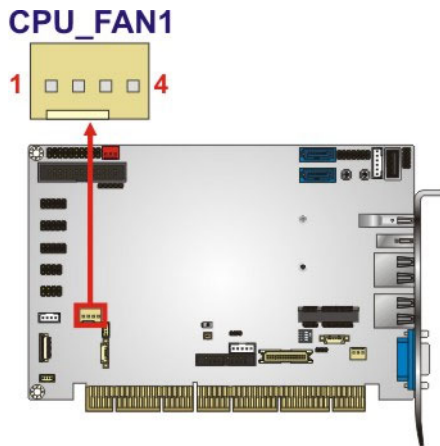

**Figure 3-8: CPU Fan Connector Location**

Pin	Description
1	GND
2	+12V
3	FANIO
4	PWM

**Table 3-10: CPU Fan Connector Pinouts**

## PCISA-BT CPU Card

### 3.2.8 Fan Connectors (System)

- CN Label:** SYS\_FAN1
- CN Type:** 3-pin wafer, p=2.54 mm
- CN Location:** See **Figure 3-9**
- CN Pinouts:** See **Table 3-11**

Each fan connector attaches to a system cooling fan.

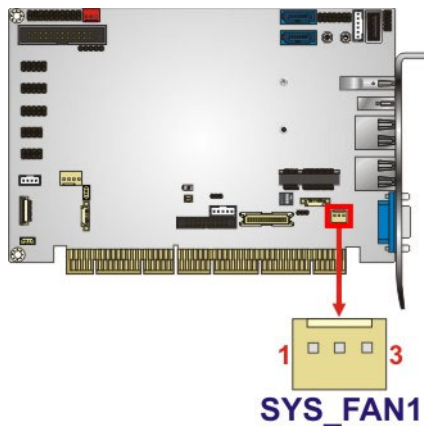

**Figure 3-9: System Fan Connector Locations**

Pin	Description
1	FANIO
2	+12V
3	GND

**Table 3-11: System Fan Connector Pinouts**

### 3.2.9 Front Panel Connector

- CN Label:** F\_PANEL1
- CN Type:** 14-pin header, p=2.54 mm
- CN Location:** See **Figure 3-10**
- CN Pinouts:** See **Table 3-12**

The front panel connector connects to the indicator LEDs and buttons on the computer's front panel.



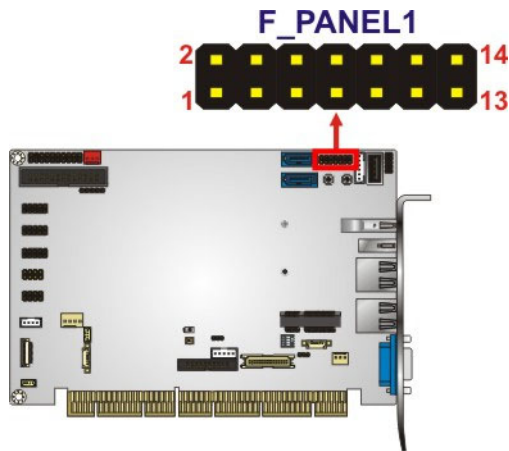

**Figure 3-10: Front Panel Connector Location**

Function	Pin	Description	Function	Pin	Description
Power LED	1	+5V	Speaker	2	BEEP_PWR
	3	NC		4	NC
	5	GND		6	NC
Power Button	7	PWRBTN_SW#		8	PC_BEEP
	9	GND	10	NC	
HDD LED	11	+5V	Reset	12	EXTRST-
	13	SATA_LED#		14	GND

**Table 3-12: Front Panel Connector Pinouts**

### 3.2.10 I<sup>2</sup>C Connector

- CN Label:** I2C\_1
- CN Type:** 4-pin wafer, p=1.25 mm
- CN Location:** See **Figure 3-11**
- CN Pinouts:** See **Table 3-13**

The I<sup>2</sup>C connector is used to connect I<sup>2</sup>C-bus devices to the motherboard.

**PCISA-BT CPU Card**

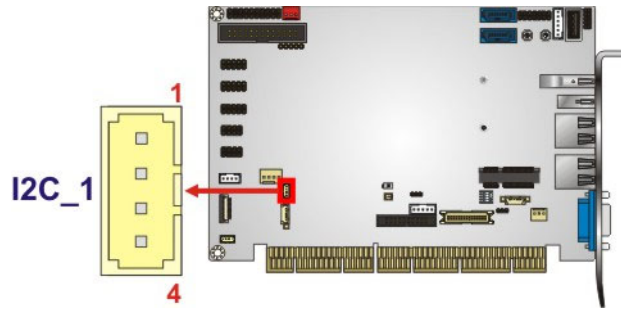

**Figure 3-11: I<sup>2</sup>C Connector Location**

Pin	Description
1	GND
2	PCH_GP38
3	PCH_GP39
4	+5V

**Table 3-13: I<sup>2</sup>C Connector Pinouts**

**3.2.11 Infrared Interface Connector**

- CN Label:** IR1
- CN Type:** 5-pin header, p=2.54 mm
- CN Location:** See **Figure 3-12**
- CN Pinouts:** See **Table 3-14**

The infrared connector attaches to an infrared receiver for use with remote controls.

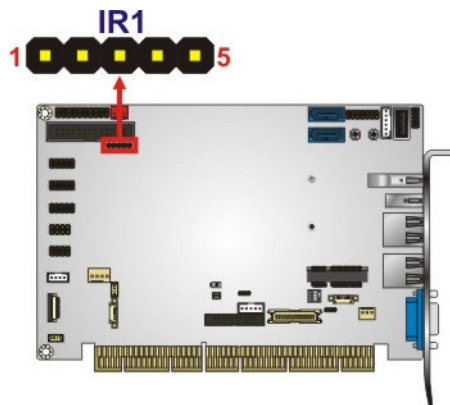

**Figure 3-12: Infrared Connector Location**

Pin	Description
1	+V5S
2	NC
3	IR-RX
4	GND
5	IR-TX

**Table 3-14: Infrared Connector Pinouts**

### 3.2.12 Internal DisplayPort Connector

- CN Label:** DP1
- CN Type:** 20-pin box header, p=2 mm
- CN Location:** See **Figure 3-13**
- CN Pinouts:** See **Table 3-15**

The DisplayPort connector supports HDMI, LVDS, VGA, DVI and DisplayPort graphics interfaces with up to 3840x2160 resolutions.

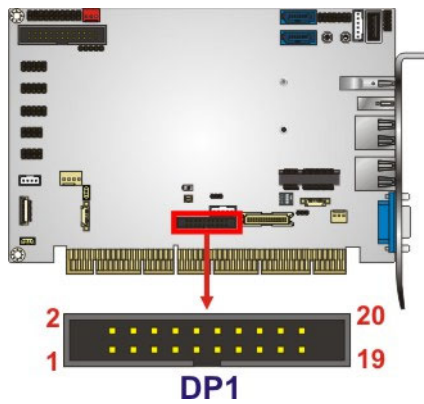

**Figure 3-13: Internal DisplayPort Connector Location**

Pin	Description	Pin	Description
1	HPD	11	LANE3N
2	AUXP	12	GND
3	GND	13	GND
4	AUXN	14	LANE0P
5	AUX_CTRL_DET_D	15	LANE1P

## PCISA-BT CPU Card

Pin	Description	Pin	Description
6	GND	16	LANE0N
7	GND	17	LANE1N
8	LANE2P	18	+3.3V
9	LANE3P	19	+5V
10	LANE2N	20	N/A

**Table 3-15: Internal DisplayPort Connector Pinouts**

### 3.2.13 Keyboard and Mouse Connector

**CN Label:** KB\_MS1

**CN Type:** 6-pin wafer, p=2 mm

**CN Location:** See **Figure 3-14**

**CN Pinouts:** See **Table 3-16**

The keyboard and mouse connector connects to a PS/2 Y-cable that can be connected to a PS/2 keyboard and mouse.

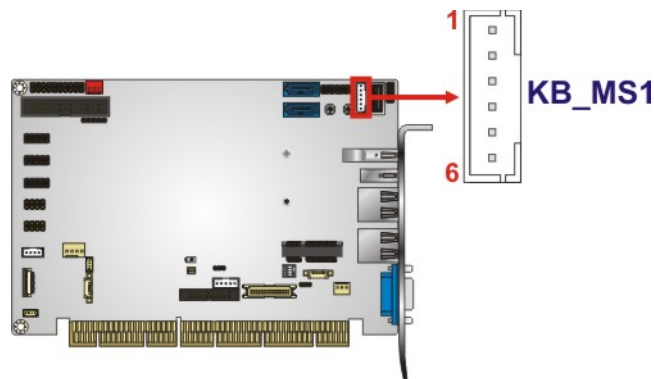

**Figure 3-14: Keyboard and Mouse Connector Location**

Pin	Description
1	VCC
2	Mouse Data
3	Mouse Clock
4	Keyboard Data

Pin	Description
5	Keyboard Clock
6	GND

**Table 3-16: Keyboard and Mouse Connector Pinouts**

### 3.2.14 LVDS Connector (Optional)

- CN Label:** LVDS1
- CN Type:** 30-pin crimp
- CN Location:** See **Figure 3-15**
- CN Pinouts:** See **Table 3-17**

The LVDS connector is for the LCD panel connected to the board.

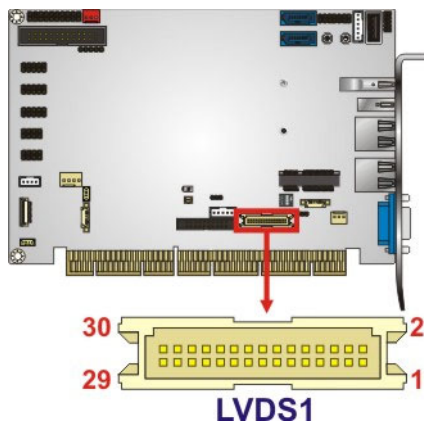

**Figure 3-15: LVDS Connector Location**

Pin	Description	Pin	Description
1	GND	2	GND
3	LVDS_A_TX0-P	4	LVDS_A_TX0-N
5	LVDS_A_TX1-P	6	LVDS_A_TX1-N
7	LVDS_A_TX2-P	8	LVDS_A_TX2-N
9	LVDS_A_TXCLK-P	10	LVDS_A_TXCLK-N
11	LVDS_A_TX3-P	12	LVDS_A_TX3-N
13	GND	14	GND
15	LVDS_B_TX0-P	16	LVDS_B_TX0-N
17	LVDS_B_TX1-P	18	LVDS_B_TX1-N



## PCISA-BT CPU Card

Pin	Description	Pin	Description
19	LVDS_B_TX2-P	20	LVDS_B_TX2-N
21	LVDS_B_TXCLK-P	22	LVDS_B_TXCLK-N
23	LVDS_B_TX3-P	24	LVDS_B_TX3-N
25	GND	26	GND
27	+LCD Vcc	28	+LCD Vcc
29	+LCD Vcc	30	+LCD Vcc

**Table 3-17: LVDS Connector Pinouts**

### 3.2.15 microSD Card Slot

- CN Label:** MICROSD1
- CN Type:** microSD card slot
- CN Location:** See **Figure 3-16**

The microSD card slot is for installing a microSD card to the system.

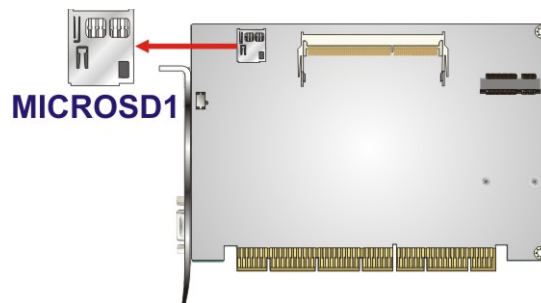

**Figure 3-16: microSD Card Slot Location**

### 3.2.16 mSATA Slot



**NOTE:**

The user can use either the mSATA slot or the **SATA2** connector. If an mSATA device is installed to the mSATA slot, the **SATA2** connector will be disabled.

- CN Label:** M\_SATA1
- CN Type:** PCIe Mini slot
- CN Location:** See **Figure 3-17**
- CN Pinouts:** See **Table 3-18**

The mSATA slot is for installing a full-size mSATA module.

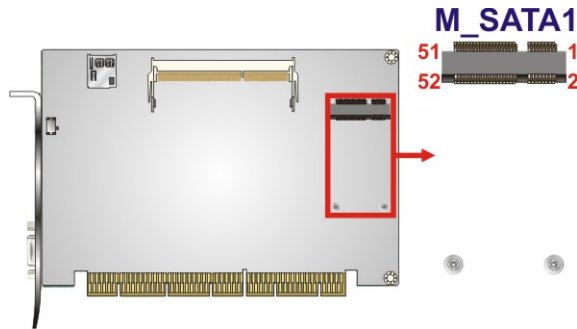

**Figure 3-17: mSATA Slot Location**

Pin	Description	Pin	Description
1	PCIE_WAKE#	2	+3.3V
3	N/C	4	GND
5	N/C	6	1.5V
7	N/C	8	N/C
9	GND	10	N/C
11	MSATA_CLK#	12	N/C
13	MSATA_CLK	14	N/C
15	GND	16	N/C
17	PLTRST_N	18	GND
19	N/C	20	+3.3V
21	GND	22	PLTRST_N
23	SATA_RX+	24	+3.3V
25	SATA_RX-	26	GND
27	GND	28	1.5V
29	GND	30	SMB_CLK
31	SATA_TX-	32	SMB_DATA
33	SATA_TX+	34	GND

## PCISA-BT CPU Card

Pin	Description	Pin	Description
35	GND	36	USB_DATA-
37	GND	38	USB_DATA+
39	+3.3V	40	GND
41	+3.3V	42	N/C
43	+3.3V	44	N/C
45	CLINK_CLK	46	N/C
47	CLINK_DATA	48	1.5V
49	CLINK_RST#	50	GND
51	MSATA_DET	52	+3.3V

**Table 3-18: mSATA Slot Pinouts**

### 3.2.17 Parallel Port Connector

- CN Label:** LPT1
- CN Type:** 26-pin box header, p=2.54 mm
- CN Location:** See **Figure 3-18**
- CN Pinouts:** See **Table 3-19**

The parallel port connector connects to a parallel port connector interface or some other parallel port device such as a printer.

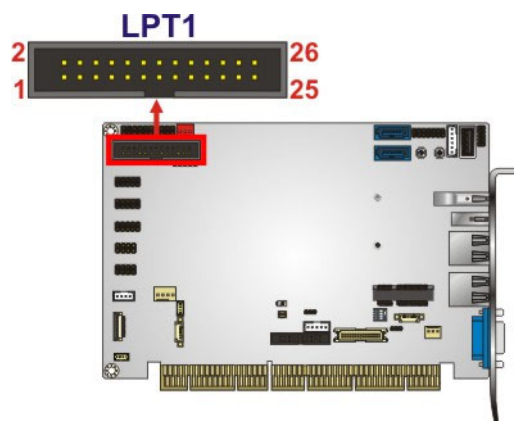

**Figure 3-18: Parallel Port Connector Location**

Pin	Description	Pin	Description
1	STROBE#	2	DATA0
3	DATA1	4	DATA2
5	DATA3	6	DATA4
7	DATA5	8	DATA6
9	DATA7	10	ACKNOWLEDGE#
11	BUSY	12	PAPER EMPTY
13	PRINTER SELECT	14	AUTO FORM FEED #
15	ERROR#	16	INITIALIZE#
17	PRINTER SELECT LN#	18	GND
19	GND	20	GND
21	GND	22	GND
23	GND	24	GND
25	GND		

**Table 3-19: Parallel Port Connector Pinouts**

### 3.2.18 PCIe Mini Slot

- CN Label:** M\_PCIE1
- CN Type:** PCIe Mini slot
- CN Location:** See **Figure 3-19**
- CN Pinouts:** See **Table 3-20**

The PCIe Mini slot is for installing a full-size/half-size PCIe Mini expansion card.

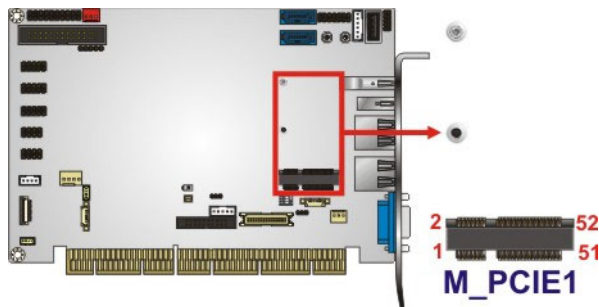

**Figure 3-19: PCIe Mini Slot Location**

## PCISA-BT CPU Card

Pin	Description	Pin	Description
1	PCIE_WAKE#	2	3.3V
3	N/C	4	GND
5	N/C	6	1.5V
7	CLKREQ#	8	UIM_PWR
9	GND	10	UIM_DATA
11	CLK-	12	UIM_CLK
13	CLK+	14	UIM_RESET
15	GND	16	UIM_VPP
17	UIM_C8	18	GND
19	UIM_C4	20	W_DISABLE#
21	GND	22	PERST#
23	PERNO	24	3.3VAUX1
25	PERPO	26	GND
27	GND	28	1.5V
29	GND	30	SMB_CLK
31	PETNO	32	SMB_DATA
33	PETPO	34	GND
35	GND	36	USB_D-
37	N/C	38	USB_D+
39	N/C	40	GND
41	N/C	42	LED_WWAN#
43	N/C	44	LED_WLAN#
45	N/C	46	LED_WPAN#
47	N/C	48	1.5V
49	N/C	50	GND
51	N/C	52	3.3V

**Table 3-20: PCIe Mini Slot Pinouts**

### 3.2.19 Power Button

**CN Label:** PWR\_SW1

**CN Type:** Push button

**CN Location:** See **Figure 3-20**



The on-board power button controls system power.

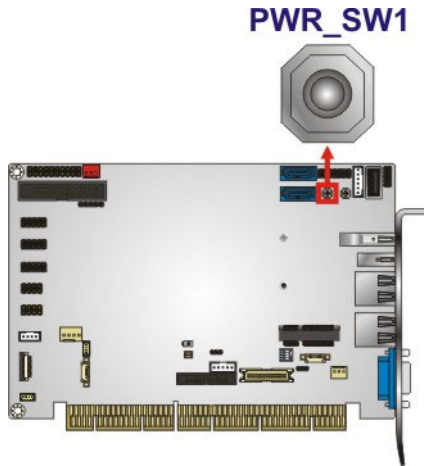
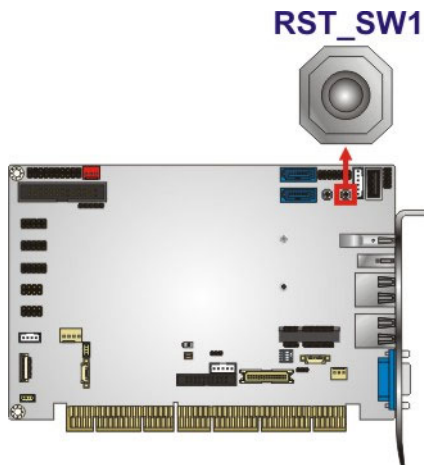

**Figure 3-20: Power Button Location**

### 3.2.20 Reset Button

- CN Label:** RST\_SW1
- CN Type:** Push button
- CN Location:** See **Figure 3-21**

Push the on-board reset button to reset the PCISA-BT.



**Figure 3-21: Reset Button Location**

**PCISA-BT CPU Card**

**3.2.21 SATA 3Gb/s Drive Connector**



**NOTE:**

The user can use either the mSATA slot or the **SATA2** connector. If an mSATA device is installed to the mSATA slot, the **SATA2** connector will be disabled.

- CN Label:** SATA1, SATA2
- CN Type:** 7-pin SATA drive connector
- CN Location:** See **Figure 3-22**
- CN Pinouts:** See **Table 3-21**

The SATA drive connectors can be connected to SATA drives and supports up to 3Gb/s data transfer rate.

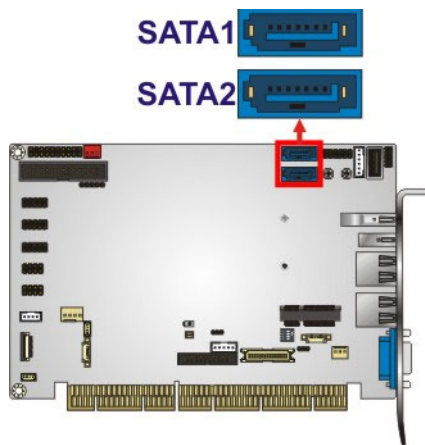

**Figure 3-22: SATA 3Gb/s Drive Connector Locations**

Pin	Description	Pin	Description
1	GND	2	TX+
3	TX-	4	GND
5	RX-	6	RX+
7	GND		

**Table 3-21: SATA 3Gb/s Drive Connector Pinouts**

**3.2.22 Serial Port Connector, RS-232**

- CN Label:** COM1, COM2
- CN Type:** 10-pin header, p=2.54 mm
- CN Location:** See **Figure 3-23**
- CN Pinouts:** See **Table 3-22**

Each of these connectors provides RS-232 connections.

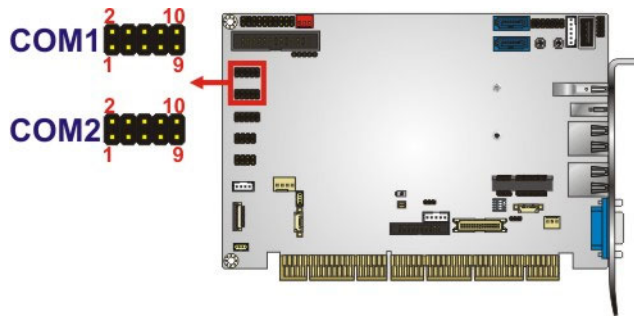

**Figure 3-23: RS-232 Serial Port Connector Locations**

Pin	Description	Pin	Description
1	DCD	2	DSR
3	RXD	4	RTS
5	TXD	6	CTS
7	DTR	8	RI
9	GND	10	GND

**Table 3-22: RS-232 Serial Port Connector Pinouts**

**3.2.23 Serial Port Connector, RS-422/485**

- CN Label:** COM3
- CN Type:** 4-pin wafer, p=2 mm
- CN Location:** See **Figure 3-24**
- CN Pinouts:** See **Table 3-23**

This connector provides RS-422 or RS-485 communications.

**PCISA-BT CPU Card**

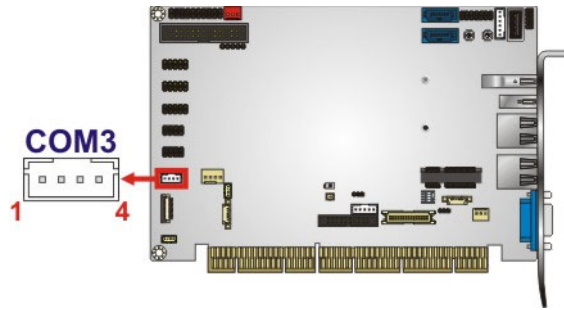

**Figure 3-24: RS-422/485 Connector Location**

Pin	Description	Pin	Description
1	RXD422-	3	TXD422+/TXD485+
2	RXD422+	4	TXD422-/TXD485-

**Table 3-23: RS-422/485 Connector Pinouts**

Use the optional RS-422/485 cable to connect to a serial device. The pinouts of the DB-9 connector are listed below.

RS-422 Pinouts	RS-485 Pinouts

**Table 3-24: DB-9 RS-422/485 Pinouts**

**3.2.24 SMBus Connector**

- CN Label:** SMBUS1
- CN Type:** 4-pin wafer, p=1.25 mm
- CN Location:** See **Figure 3-25**
- CN Pinouts:** See **Table 3-25**

The SMBus (System Management Bus) connector provides low-speed system management communications.

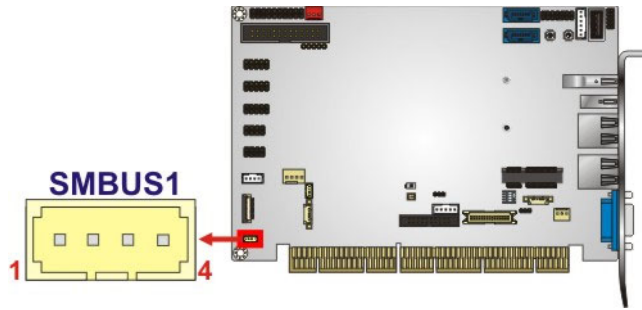

**Figure 3-25: SMBus Connector Location**

Pin	Description
1	GND
2	SMB_DATA
3	SMB_CLK
4	+5V

**Table 3-25: SMBus Connector Pinouts**

### 3.2.25 SO-DIMM Slot

- CN Label:** DIMM1
- CN Type:** DDR3L SO-DIMM slot
- CN Location:** See **Figure 3-26**

The SO-DIMM slot is for installing a DDR3L SO-DIMM.

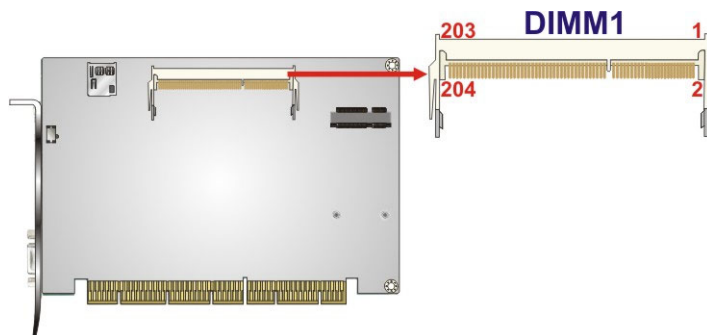

**Figure 3-26: SO-DIMM Slot Location**



## PCISA-BT CPU Card

### 3.2.26 SPI Flash Connector

- CN Label:** JSPI1
- CN Type:** 6-pin wafer, p=2.54 mm
- CN Location:** See **Figure 3-27**
- CN Pinouts:** See **Table 3-26**

The SPI flash connector is used to flash the SPI ROM.

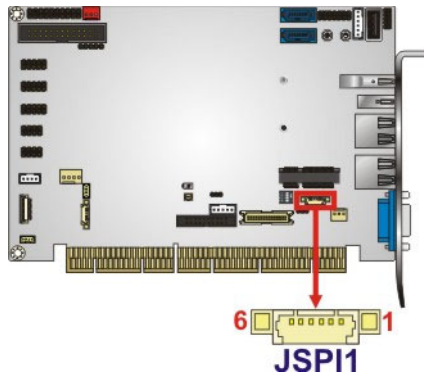

**Figure 3-27: SPI Flash Connector Location**

Pin	Description	Pin	Description
1	+1.8V	2	SPI_CS#
3	SPI_SO	4	SPI_CLK
5	SPI_SI	6	GND

**Table 3-26: SPI Flash Connector Pinouts**

### 3.2.27 SPI Flash Connector, EC

- CN Label:** JSPI2
- CN Type:** 6-pin wafer, p=2.54 mm
- CN Location:** See **Figure 3-28**
- CN Pinouts:** See **Table 3-27**

The SPI flash connector is used to flash the EC ROM.

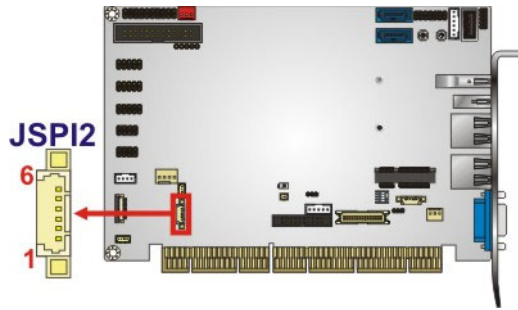

**Figure 3-28: SPI EC Flash Connector Location**

Pin	Description	Pin	Description
1	+3.3V	2	SPI_CS#
3	SPI_SO	4	SPI_CLK
5	SPI_SI	6	GND

**Table 3-27: SPI EC Flash Connector Pinouts**

### 3.2.28 TPM Connector

- CN Label:** TPM1
- CN Type:** 20-pin header, p=2.54 mm
- CN Location:** See **Figure 3-29**
- CN Pinouts:** See **Table 3-28**

The TPM connector connects to a TPM module.

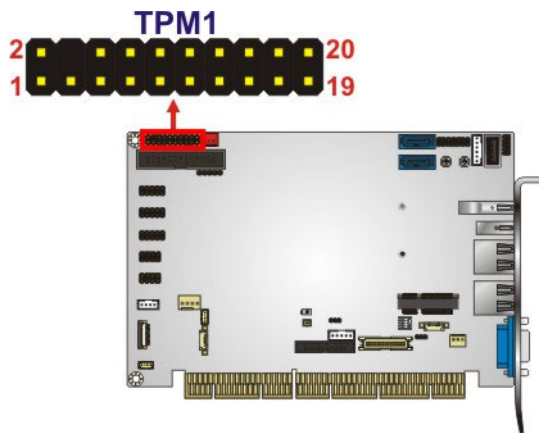

**Figure 3-29: TPM Connector Location**

**PCISA-BT CPU Card**

Pin	Description	Pin	Description
1	LCLK	2	GND
3	LFRAME#	4	KEY
5	LRERST#	6	+5V
7	LAD3	8	LAD2
9	+3.3V	10	LAD1
11	LAD0	12	GND
13	SCL	14	SDA
15	SB3V	16	SERIRQ
17	GND	18	GLKRUN#
19	LPCPD#	20	LDRO#

**Table 3-28: TPM Connector Pinouts**

**3.2.29 USB 2.0 Connector (Type A)**

- CN Label:** USB5
- CN Type:** USB Type A
- CN Location:** See **Figure 3-30**
- CN Pinouts:** See **Table 3-29**

The USB Type A connector connects to a USB 2.0/1.1 device.

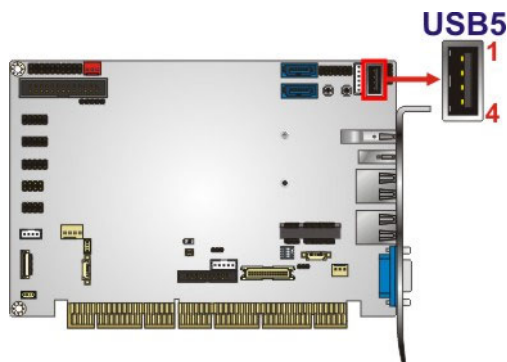

**Figure 3-30: USB 2.0 Connector (Type A) Pinout Location**

Pin	Description
1	VCC
2	DATA-
3	DATA+
4	GROUND

**Table 3-29: USB 2.0 Connector (Type A) Pinouts**

### 3.2.30 USB 2.0 Connectors

- CN Label:** USB3, USB4
- CN Type:** 8-pin header, p=2.54 mm
- CN Location:** See **Figure 3-31**
- CN Pinouts:** See **Table 3-30**

The USB 2.0 connectors connect to USB 2.0 devices. Each pin header provides two USB 2.0 ports.

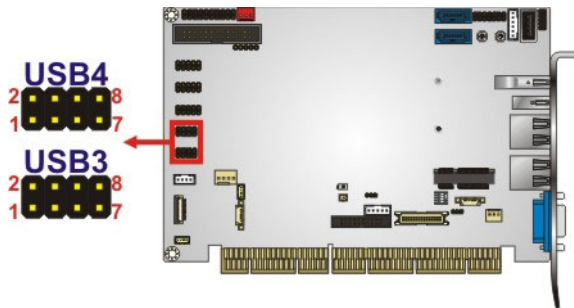

**Figure 3-31: USB 2.0 Connector Pinout Locations**

Pin	Description	Pin	Description
1	VCC	2	GND
3	USB_DATA-	4	USB_DATA+
5	USB_DATA+	6	USB_DATA-
7	GND	8	VCC

**Table 3-30: USB 2.0 Connector Pinouts**

### 3.3 External Peripheral Interface Connector Panel

The figure below shows the external peripheral interface connector (EPIC) panel. The EPIC panel consists of the following:

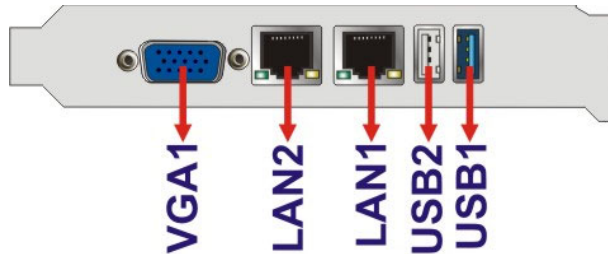

Figure 3-32: External Peripheral Interface Connector

#### 3.3.1 Ethernet Connectors

- CN Label:** LAN1, LAN2
- CN Type:** RJ-45
- CN Location:** See Figure 3-32
- CN Pinouts:** See Table 3-31

Each LAN connector connects to a local network

Pin	Description	Pin	Description
1	MDIA3-	5	MDIA2+
2	MDIA3+	6	MDIA1+
3	MDIA1-	7	MDIA0-
4	MDIA2-	8	MDIA0+

Table 3-31: LAN Pinouts

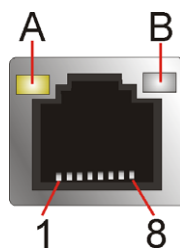

Figure 3-33: Ethernet Connector



### 3.3.2 USB 2.0 Connector

- CN Label:** USB2
- CN Type:** USB 2.0
- CN Location:** See **Figure 3-32**
- CN Pinouts:** See **Table 3-32**

There is one external USB 2.0 connector on the PCISA-BT.

Pin	Description	Pin	Description
1	VCC	3	USB_DATA+
2	USB_DATA-	4	GND

**Table 3-32: USB 2.0 Port Pinouts**

### 3.3.3 USB 3.0 Connector

- CN Label:** USB1
- CN Type:** USB 3.0
- CN Location:** See **Figure 3-32**
- CN Pinouts:** See **Table 3-33**

There is one external USB 3.0 connector on the PCISA-BT.

Pin	Description	Pin	Description
1	+5V	6	USB3.0RX+
2	USB_DATA-	7	AGND
3	USB_DATA+	8	USB3.0 TX+
4	GND	9	USB3.0 TX-
5	USB3.0RX-		

**Table 3-33: USB 3.0 Port Pinouts**

**PCISA-BT CPU Card**

**3.3.4 VGA Connector**

- CN Label:** VGA1
- CN Type:** 15-pin VGA
- CN Location:** See **Figure 3-32**
- CN Pinouts:** See **Table 3-34**

The 15-pin VGA connector connects to a monitor that accepts a standard VGA input.

Pin	Description	Pin	Description
1	RED	2	GREEN
3	BLUE	4	NC
5	GND	6	GND
7	GND	8	GND
9	VCC	10	GND
11	NC	12	DDCDA
13	HSYNC	14	VSYNC
15	DDCCLK		

**Table 3-34: VGA Connector Pinouts**

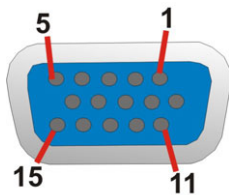

**Figure 3-34: VGA Connector**

Chapter

4

# Installation

---

## PCISA-BT CPU Card

### 4.1 Anti-static Precautions

---



#### WARNING:

Failure to take ESD precautions during the installation of the PCISA-BT may result in permanent damage to the PCISA-BT and severe injury to the user.

---

Electrostatic discharge (ESD) can cause serious damage to electronic components, including the PCISA-BT. Dry climates are especially susceptible to ESD. It is therefore critical that whenever the PCISA-BT or any other electrical component is handled, the following anti-static precautions are strictly adhered to.

- **Wear an anti-static wristband:** - Wearing a simple anti-static wristband can help to prevent ESD from damaging the board.
- **Self-grounding:**- Before handling the board touch any grounded conducting material. During the time the board is handled, frequently touch any conducting materials that are connected to the ground.
- **Use an anti-static pad:** When configuring the PCISA-BT, place it on an anti-static pad. This reduces the possibility of ESD damaging the PCISA-BT.
- **Only handle the edges of the PCB:-** When handling the PCB, hold the PCB by the edges.

### 4.2 Installation Considerations

---



#### NOTE:

The following installation notices and installation considerations should be read and understood before installation. All installation notices must be strictly adhered to. Failing to adhere to these precautions may lead to severe damage and injury to the person performing the installation.

---

**WARNING:**

The installation instructions described in this manual should be carefully followed in order to prevent damage to the components and injury to the user.

Before and during the installation please **DO** the following:

- Read the user manual:
  - The user manual provides a complete description of the PCISA-BT installation instructions and configuration options.
- Wear an electrostatic discharge cuff (ESD):
  - Electronic components are easily damaged by ESD. Wearing an ESD cuff removes ESD from the body and helps prevent ESD damage.
- Place the PCISA-BT on an anti-static pad:
  - When installing or configuring the motherboard, place it on an anti-static pad. This helps to prevent potential ESD damage.
- Turn all power to the PCISA-BT off:
  - When working with the PCISA-BT, make sure that it is disconnected from all power supplies and that no electricity is being fed into the system.

Before and during the installation of the PCISA-BT, **DO NOT:**

- Remove any of the stickers on the PCB board. These stickers are required for warranty validation.
- Use the product before verifying all the cables and power connectors are properly connected.
- Allow screws to come in contact with the PCB circuit, connector pins, or its components.



## PCISA-BT CPU Card

### 4.3 SO-DIMM Installation

To install a SO-DIMM, please follow the steps below and refer to **Figure 4-1**.

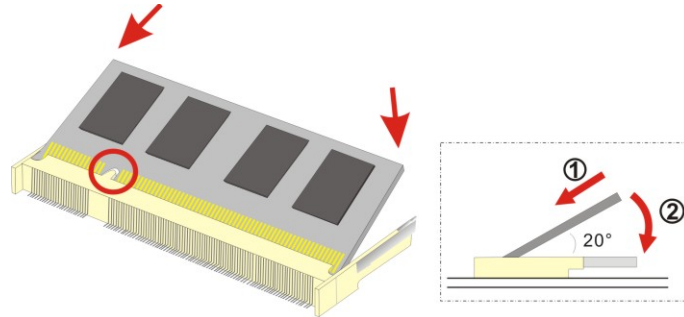

**Figure 4-1: SO-DIMM Installation**

- Step 1:** Locate the **SO-DIMM socket** on the solder side of the PCISA-BT. Place the board on an anti-static mat.
- Step 2:** Align the **SO-DIMM with the socket**. Align the notch on the memory with the notch on the memory socket.
- Step 3:** Insert the **SO-DIMM**. Push the memory in at a 20° angle. (See **Figure 4-1**)
- Step 4:** **Seat the SO-DIMM**. Gently push downwards and the arms clip into place. (See **Figure 4-1**)

### 4.4 Full-size PCIe Mini Card Installation

The PCIe Mini card slot allows installation of either a full-size or half-size PCIe Mini card. To install a full-size PCIe Mini card, please follow the steps below.

- Step 1:** Locate the **PCIe Mini card slot**. See **Figure 3-19**.
- Step 2:** Remove the **retention screw**. Remove the retention screw as shown in **Figure 4-2**.

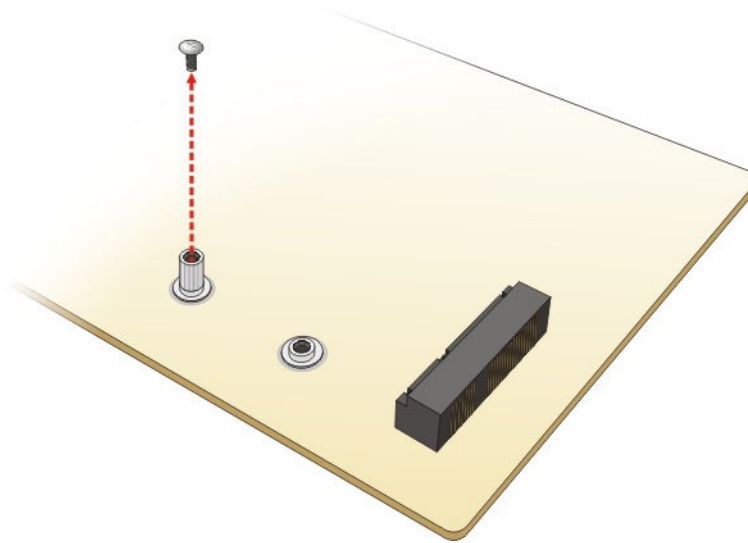

**Figure 4-2: Removing the Retention Screw**

**Step 3:** Insert into the socket at an angle. Line up the notch on the card with the notch on the slot. Slide the PCIe Mini card into the socket at an angle of about 20° (Figure 4-3).

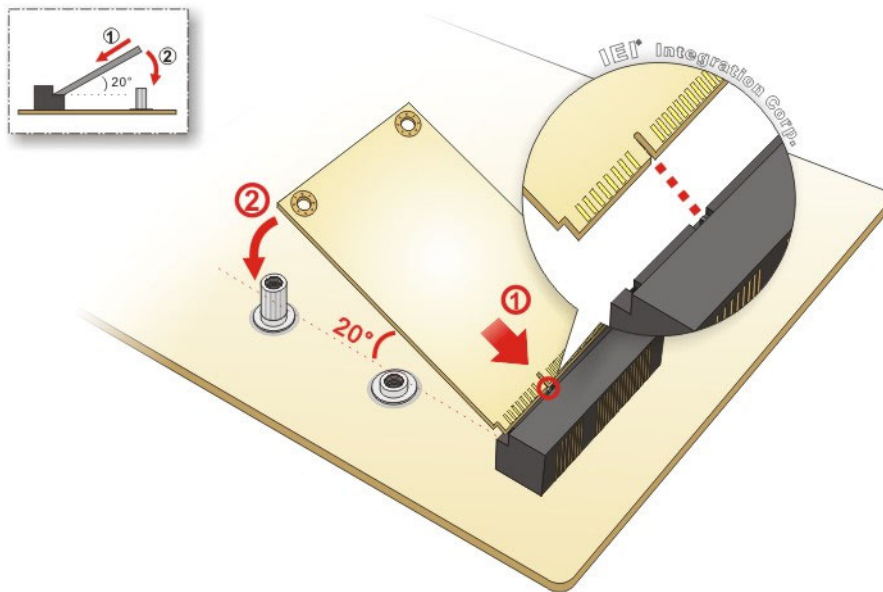

**Figure 4-3: Inserting the Full-size PCIe Mini Card into the Slot at an Angle**

## PCISA-BT CPU Card

**Step 4:** **Secure the full-size PCIe Mini card.** Secure the full-size PCIe Mini card with the retention screw previously removed (**Figure 4-4**).

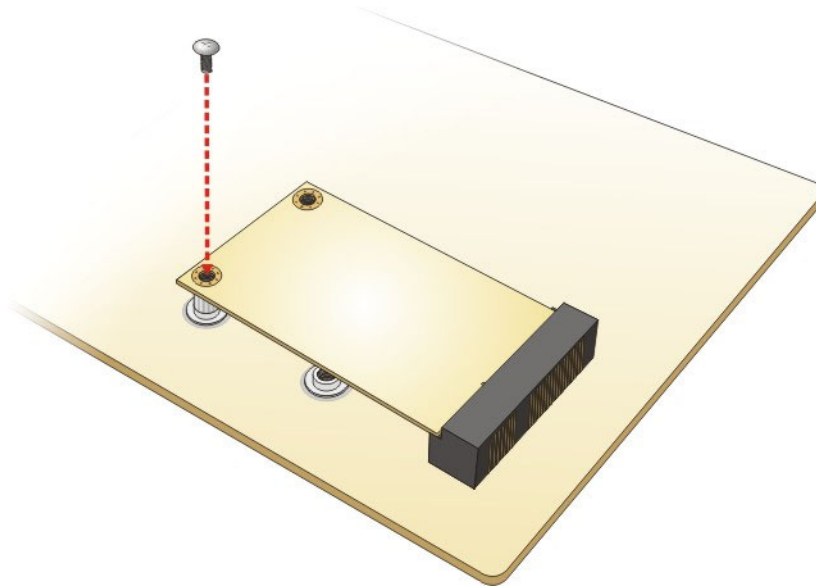

**Figure 4-4: Securing the Full-size PCIe Mini Card**

### 4.5 Half-size PCIe Mini Card Installation

The PCIe Mini card slot allows installation of either a full-size or half-size PCIe Mini card. To install a half-size PCIe Mini card, please follow the steps below.

**Step 1:** **Locate the PCIe Mini card slot.** See **Figure 3-19**.

**Step 2:** **Remove the retention screw.** Remove the retention screw as shown in **Figure 4-2**.

**Step 3:** **Remove the standoff.** Unscrew and remove the standoff secured on the motherboard as shown in **Figure 4-5**.

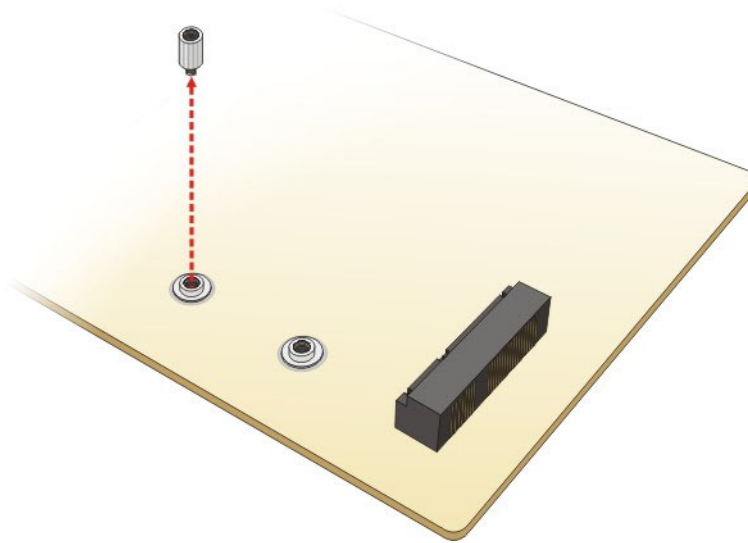

**Figure 4-5: Removing the Standoff**

**Step 4:** Install the standoff to the screw hole for the half-size PCIe Mini card. Install the previously removed standoff to the screw hole for the half-size PCIe Mini card (Figure 4-6).

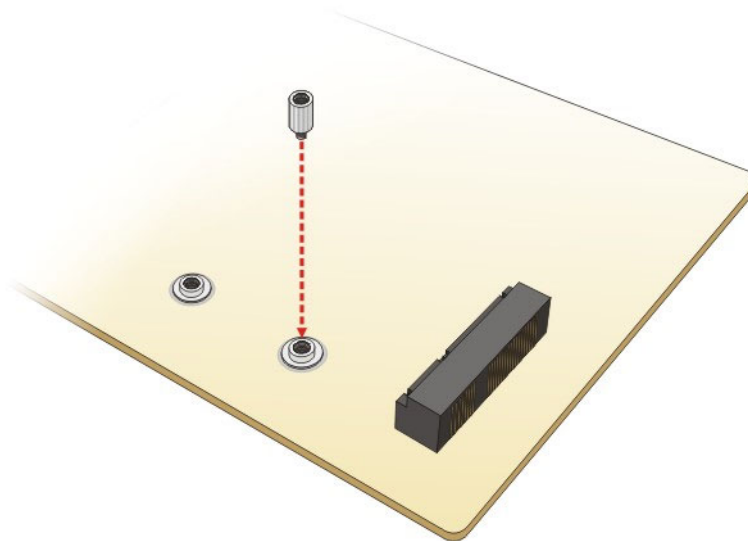

**Figure 4-6: Installing the Standoff**



## PCISA-BT CPU Card

**Step 5:** Insert into the socket at an angle. Line up the notch on the card with the notch on the slot. Slide the PCIe Mini card into the slot at an angle of about 20° (Figure 4-7).

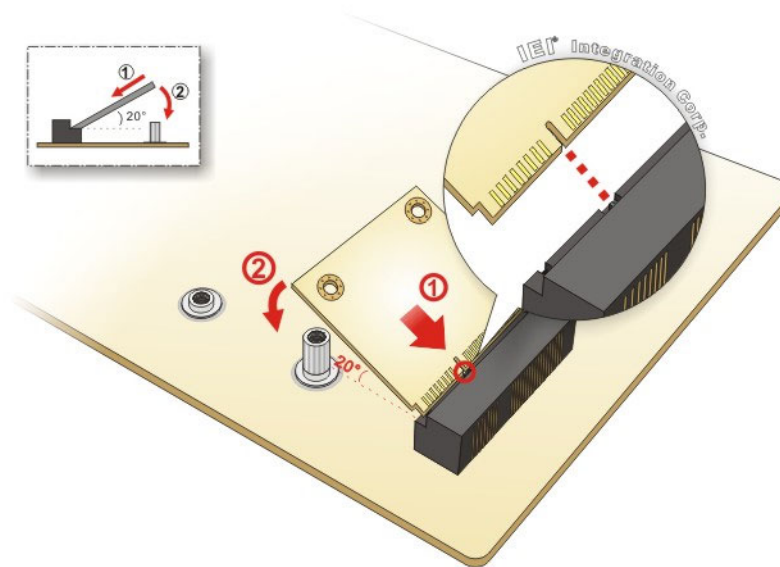

Figure 4-7: Inserting the Half-size PCIe Mini Card into the Slot at an Angle

**Step 6:** Secure the half-size PCIe Mini card. Secure the half-size PCIe Mini card with the retention screw previously removed (Figure 4-8).

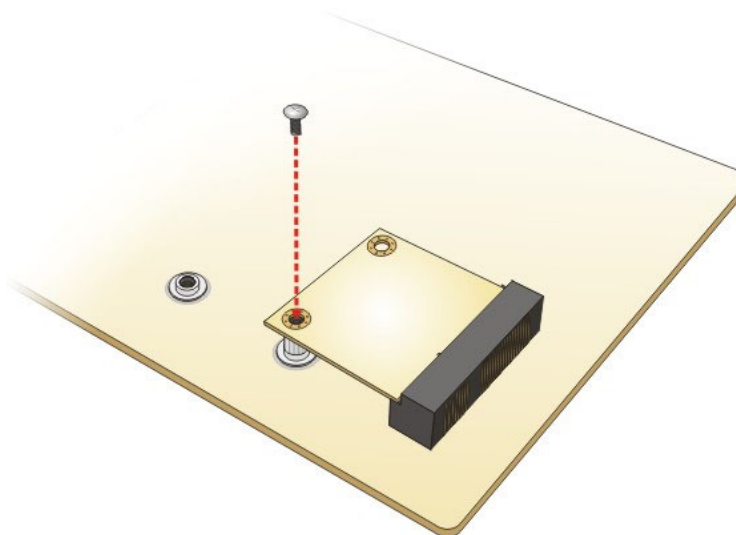

Figure 4-8: Securing the Half-size PCIe Mini Card



## 4.6 mSATA Module Installation



### NOTE:

The user can use either the mSATA slot or the **SATA2** connector. If an mSATA device is installed to the mSATA slot (**M\_SATA1**), the **SATA2** connector will be disabled.

To install an mSATA module, please follow the steps below.

**Step 1:** **Locate the mSATA slot.** The mSATA slot is located on the solder side of the motherboard (**Figure 3-17**).

**Step 2:** **Remove the retention screws.** Remove the two retention screws secured on the motherboard as shown in **Figure 4-9**.

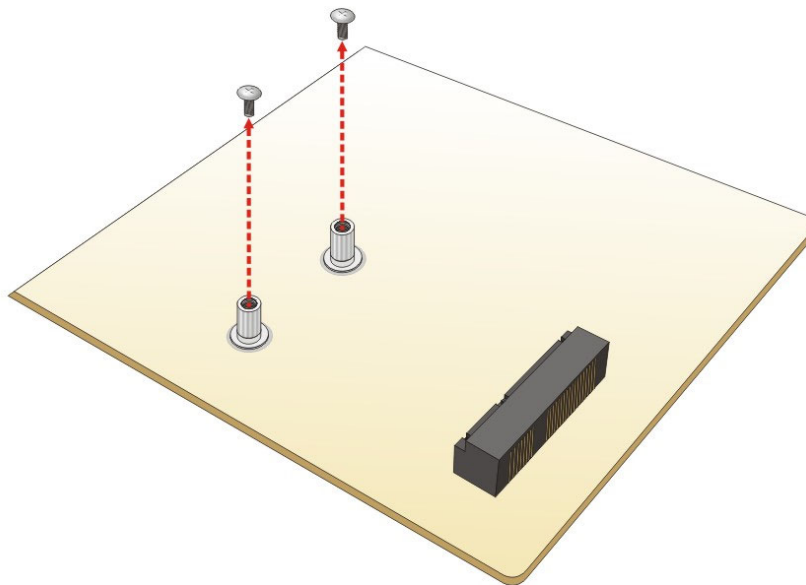

**Figure 4-9: Removing the Retention Screws for the mSATA Module**

**Step 3:** **Insert into the socket at an angle.** Line up the notch on the module with the notch on the connector. Slide the mSATA module into the socket at an angle of about 20° (**Figure 4-10**).

## PCISA-BT CPU Card

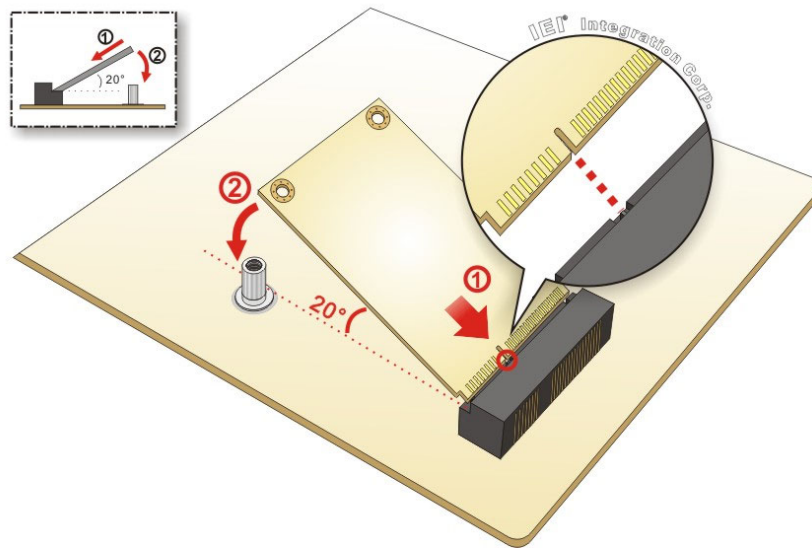

Figure 4-10: Inserting the mSATA Module into the Socket at an Angle

**Step 4:** **Secure the mSATA module.** Secure the mSATA module with the retention screws previously removed (Figure 4-11).

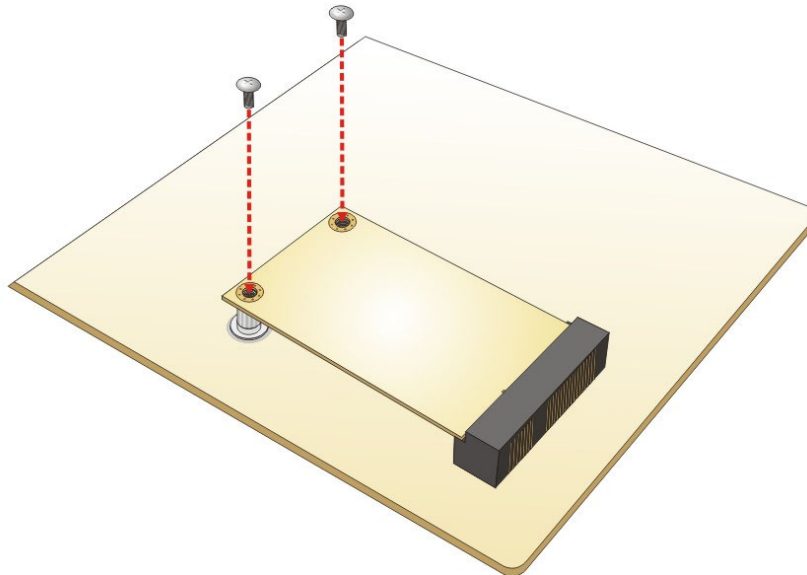

Figure 4-11: Securing the mSATA Module

## 4.7 System Configuration

The system configuration should be performed before installation.

### 4.7.1 AT/ATX Power Mode Setting

The AT and ATX power mode selection is made through the AT/ATX power mode switch which is shown in **Figure 4-12**.

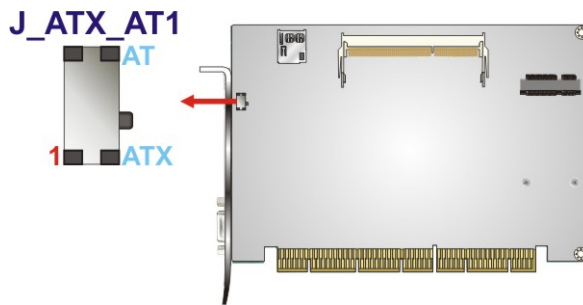

**Figure 4-12: AT/ATX Power Mode Switch Location**

Setting	Description
1-2 (down)	ATX power mode (default)
2-3 (up)	AT power mode

**Table 4-1: AT/ATX Power Mode Switch Settings**

### 4.7.2 Clear CMOS Button

To reset the BIOS, remove the on-board battery and press the clear CMOS button for three seconds or more. The clear CMOS button location is shown in **Figure 4-13**.

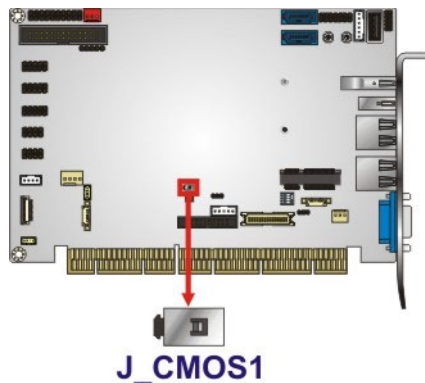

**Figure 4-13: Clear CMOS Button Location**

**4.7.3 LVDS Panel Type Selection (Optional)**

- Jumper Label:** SW1
- Jumper Type:** DIP switch
- Jumper Settings:** See Table 4-2
- Jumper Location:** See Figure 4-14

Use the DIP switch to select the resolution of the LCD panel connected to the LVDS1 connector.

\* ON=0, OFF=1

<b>SW1 (4-3-2-1)</b>	<b>EDID Resolution</b>	<b>Color Depth</b>	<b>Channel</b>
0000	800 x 600 @ 60Hz	18-bit	Single
0001	1024 x 768 @ 60Hz	18-bit	Single
0010	1024 x 768 @ 60Hz	24-bit	Single
0011	1280 x 768 @ 60Hz	18-bit	Single
0100	1280 x 800 @ 60Hz	18-bit	Single
0101	1280 x 960 @ 60Hz	18-bit	Single
0110	1280 x 1024 @ 60Hz	24-bit	Single
0111	1366 x 768 @ 60Hz	18-bit	Single
1000	1366 x 768 @ 60Hz	24-bit	Dual
1001	1440 x 900 @ 60Hz	24-bit	Single
1010	1440 x 1050 @ 60Hz	24-bit	Single
1011	1600 x 900 @ 60Hz	24-bit	Dual
1100	1680 x 1050 @ 60Hz	24-bit	Dual
1101	1600 x 1200 @ 60Hz	24-bit	Dual
1110	1920 x 1080 @ 60Hz	24-bit	Dual
1111	1920 x 1200 @ 60Hz	24-bit	Dual

**Table 4-2: LVDS Panel Type Selection**

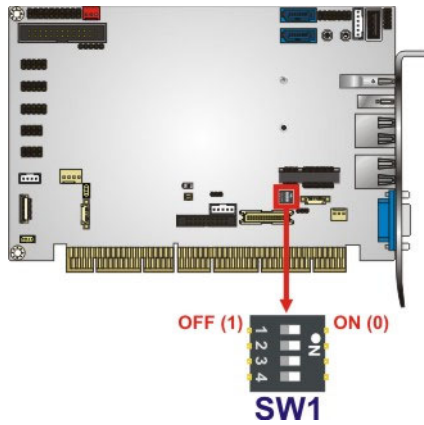

**Figure 4-14: LVDS Panel Type Selection Switch Location**

**4.7.4 LVDS Backlight Mode Selection (Optional)**

- Jumper Label:** JP3
- Jumper Type:** 3-pin header
- Jumper Settings:** See Table 4-3
- Jumper Location:** See Figure 4-15

The LVDS backlight mode selection jumper allows setting the backlight mode of the monitor connected to the LVDS connector.

Setting	Description
Short 1-2	DC mode (Default)
Short 2-3	PWM mode

**Table 4-3: LVDS Backlight Mode Selection Jumper Settings**

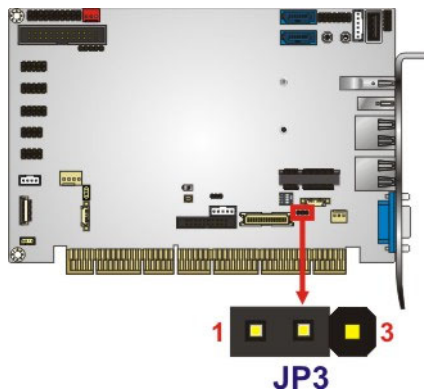

**Figure 4-15: LVDS Backlight Mode Selection Jumper Location**



**PCISA-BT CPU Card**

**4.7.5 LVDS Voltage Selection (Optional)**



**WARNING:**

Permanent damage to the screen and PCISA-BT may occur if the wrong voltage is selected with this jumper. Please refer to the user guide that came with the monitor to select the correct voltage.

- Jumper Label:** JP2
- Jumper Type:** 3-pin header
- Jumper Settings:** See Table 4-4
- Jumper Location:** See Figure 4-16

The LVDS voltage selection jumper allows setting the voltage provided to the monitor connected to the LVDS connector.

Setting	Description
Short 1-2	3.3V (Default)
Short 2-3	5V

**Table 4-4: LVDS Voltage Selection Jumper Settings**

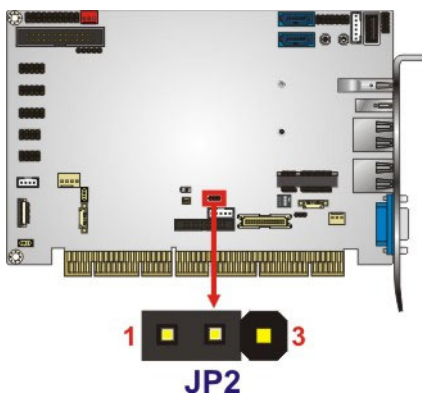

**Figure 4-16: LVDS Voltage Selection Jumper Location**

## 4.8 Internal Peripheral Device Connections

This section outlines the installation of peripheral devices to the onboard connectors.

### 4.8.1 SATA Drive Connection

The PCISA-BT is shipped with two SATA drive cables. To connect the SATA drives to the connectors, please follow the steps below.

**Step 1:** **Locate the connectors.** The locations of the SATA drive connectors are shown in **Chapter 3**.

**Step 2:** **Insert the cable connector.** Insert the cable connector into the on-board SATA drive connector until it clips into place. See **Figure 4-17**.

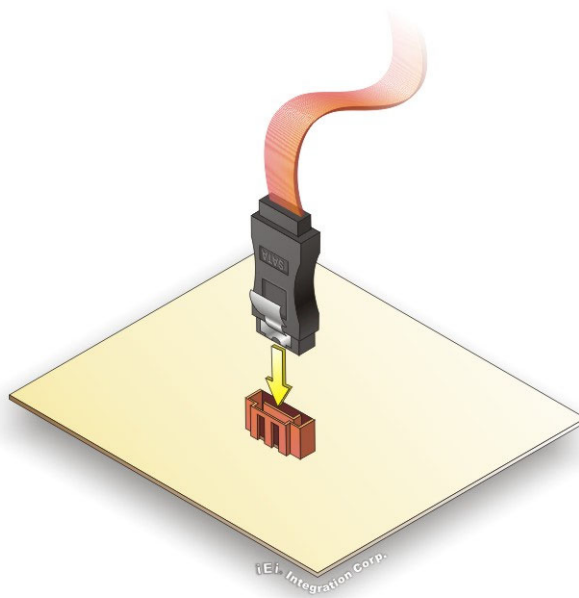
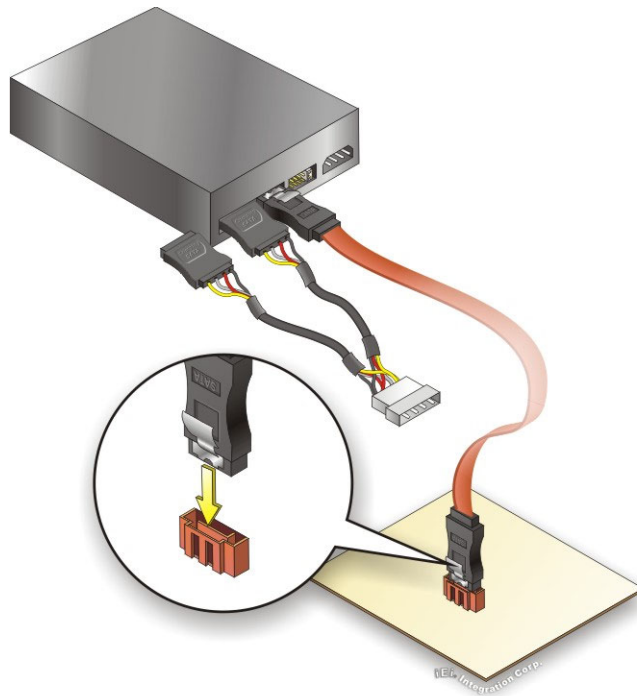

**Figure 4-17: SATA Drive Cable Connection**

**Step 3:** **Connect the cable to the SATA disk.** Connect the connector on the other end of the cable to the connector at the back of the SATA drive. See **Figure 4-18**.

**Step 4:** **Connect the SATA power cable.** Connect the SATA power connector to the back of the SATA drive. See **Figure 4-18**.

**PCISA-BT CPU Card**



**Figure 4-18: SATA Power Drive Connection**

The SATA power cable can be bought from IEI. See Optional Items in Section 2.4.

Chapter

**5**

**BIOS**

---

## 5.1 Introduction

The BIOS is programmed onto the BIOS chip. The BIOS setup program allows changes to certain system settings. This chapter outlines the options that can be changed.



### NOTE:

Some of the BIOS options may vary throughout the life cycle of the product and are subject to change without prior notice.

### 5.1.1 Starting Setup

The UEFI BIOS is activated when the computer is turned on. The setup program can be activated in one of two ways.

1. Press the **DEL** or **F2** key as soon as the system is turned on or
2. Press the **DEL** or **F2** key when the “**Press DEL or F2 to enter SETUP**” message appears on the screen.

If the message disappears before the **DEL** or **F2** key is pressed, restart the computer and try again.

### 5.1.2 Using Setup

Use the arrow keys to highlight items, press **ENTER** to select, use the PageUp and PageDown keys to change entries, press **F1** for help and press **ESC** to quit. Navigation keys are shown in the following table.

Key	Function
Up arrow	Move to previous item
Down arrow	Move to next item
Left arrow	Move to the item on the left hand side
Right arrow	Move to the item on the right hand side
+	Increase the numeric value or make changes
-	Decrease the numeric value or make changes



Key	Function
Page Up	Move to the previous page
Page Dn	Move to the next page
Esc	Main Menu – Quit and not save changes into CMOS Status Page Setup Menu and Option Page Setup Menu -- Exit current page and return to Main Menu
F1	General help, only for Status Page Setup Menu and Option Page Setup Menu
F2	Load previous values
F3	Load optimized defaults
F4	Save changes and Exit BIOS

Table 5-1: BIOS Navigation Keys

### 5.1.3 Getting Help

When **F1** is pressed, a small help window describing the appropriate keys to use and the possible selections for the highlighted item appears. To exit the Help Window, press **Esc**.

### 5.1.4 Unable to Reboot after Configuration Changes

If the computer cannot boot after changes to the system configuration is made, CMOS defaults. Use the clear CMOS button described in **Chapter 4**.

### 5.1.5 BIOS Menu Bar

The **menu bar** on top of the BIOS screen has the following main items:

- Main – Changes the basic system configuration.
- Advanced – Changes the advanced system settings.
- Chipset – Changes the chipset settings.
- Security – Sets User and Supervisor Passwords.
- Boot – Changes the system boot configuration.
- Save & Exit – Selects exit options and loads default settings

The following sections completely describe the configuration options found in the menu items at the top of the BIOS screen and listed above.

## PCISA-BT CPU Card

### 5.2 Main

The **Main** BIOS menu (**BIOS Menu 1**) appears when the **BIOS Setup** program is entered.

The **Main** menu gives an overview of the basic system information.

Aptio Setup Utility - Copyright (C) 2013 American Megatrends, Inc.					
Main	Advanced	Chipset	Security	Boot	Save & Exit
BIOS Information					Set the Date. Use Tab to switch between Date elements.
BIOS Vendor			American Megatrends		
Core Version			5.009		
Compliance			UEFI 2.3; PI 1.2		
Project Version			B341AI10.ROM		
Build Date and Time			04/20/2015 18:18:06		
iWDD Vendor			iEi		
iWDD Version			B341ER10.bin		
-----					
CPU Configuration					→←: Select Screen
Microcode Patch			901		↑ ↓: Select Item
BayTrail SoC			D0 Stepping		Enter: Select
Memory Information					+/-: Change Opt.
Total Memory			2048 MB (LPDDR3)		F1: General Help
TXE Information					F2: Previous Values
Sec RC Version			00.05.00.00		F3: Optimized Defaults
TXE FW Version			01.00.02.1060		F4: Save & Exit
System Date			[Wed 07/22/2015]		ESC: Exit
System Time			[15:10:27]		
Access Level			Administrator		
Version 2.16.1242. Copyright (C) 2013 American Megatrends, Inc.					

#### BIOS Menu 1: Main

The **Main** menu has two user configurable fields:

➔ **System Date [xx/xx/xx]**

Use the **System Date** option to set the system date. Manually enter the day, month and year.

➔ **System Time [xx:xx:xx]**

Use the **System Time** option to set the system time. Manually enter the hours, minutes and seconds.

### 5.3 Advanced

Use the **Advanced** menu (**BIOS Menu 2**) to configure the CPU and peripheral devices through the following sub-menus:



#### **WARNING!**

Setting the wrong values in the sections below may cause the system to malfunction. Make sure that the settings made are compatible with the hardware.

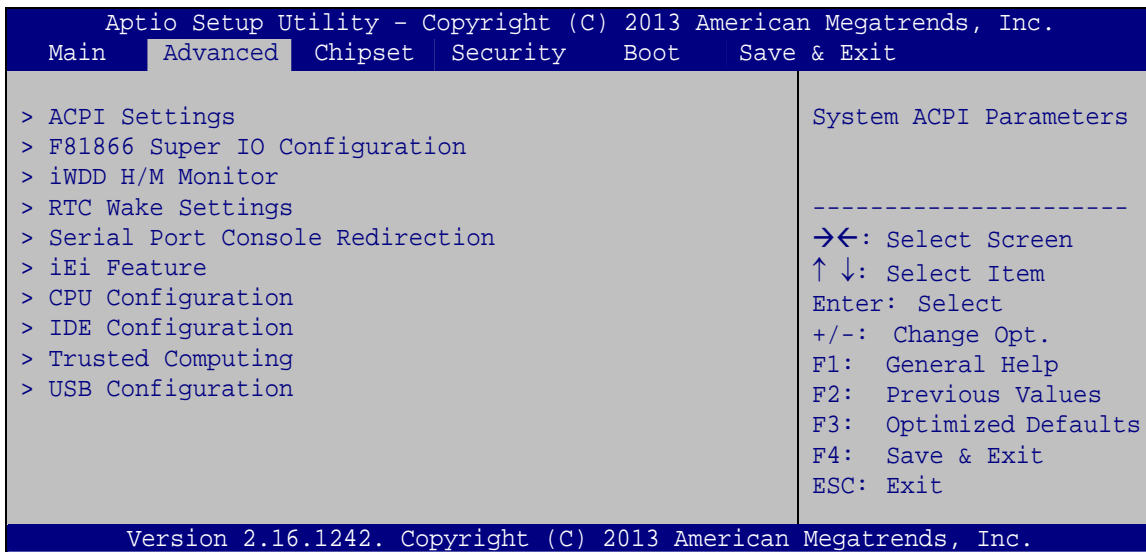

**BIOS Menu 2: Advanced**

## PCISA-BT CPU Card

### 5.3.1 ACPI Settings

The **ACPI Settings** menu (**BIOS Menu 3**) configures the Advanced Configuration and Power Interface (ACPI) options.

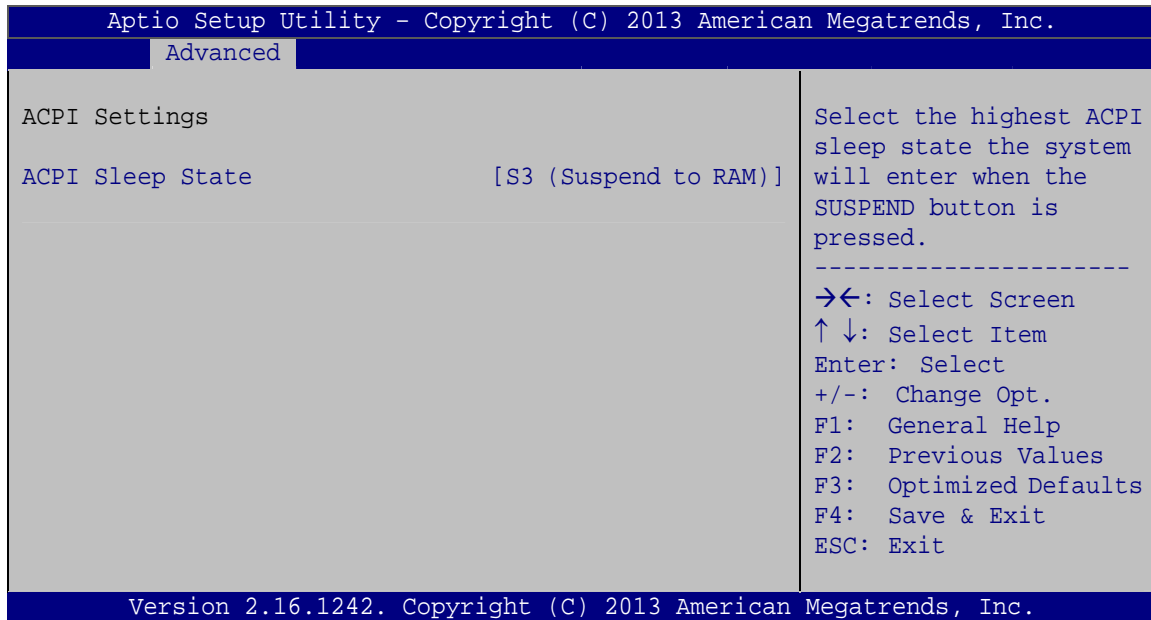

#### BIOS Menu 3: ACPI Configuration

##### → ACPI Sleep State [S3 (Suspend to RAM)]

Use the **ACPI Sleep State** option to specify the sleep state the system enters when it is not being used.

- **S3 (Suspend to RAM)**      **DEFAULT**      The caches are flushed and the CPU is powered off. Power to the RAM is maintained. The computer returns slower to a working state, but more power is saved.

### 5.3.2 F81866 Super IO Configuration

Use the **F81866 Super IO Configuration** menu (**BIOS Menu 4**) to set or change the configurations for the serial ports and parallel port.

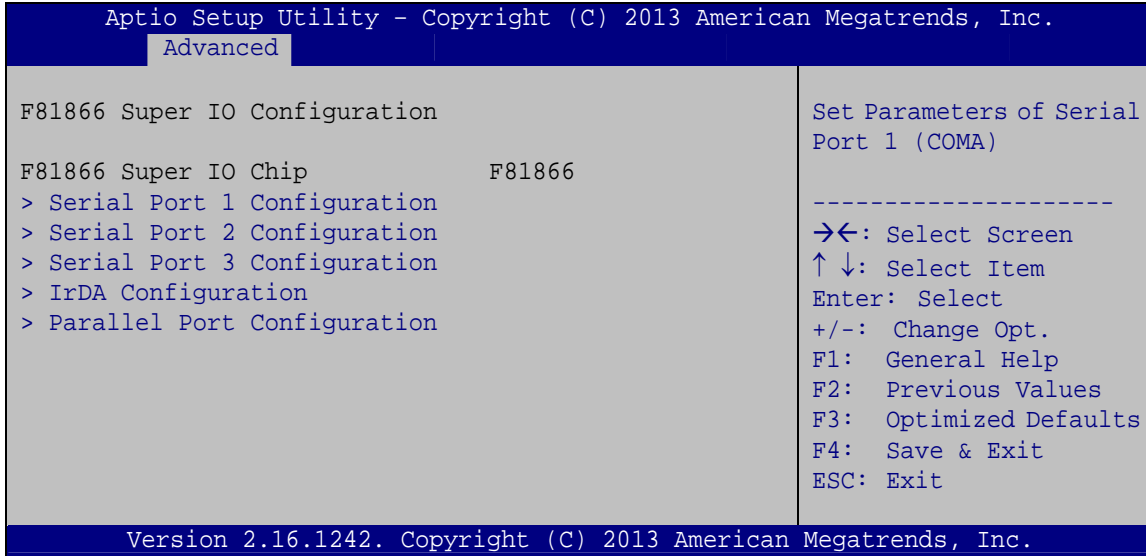

**BIOS Menu 4: F81866 Super IO Configuration**

#### 5.3.2.1 Serial Port n Configuration

Use the **Serial Port n Configuration** menu (**BIOS Menu 5**) to configure the serial port n.

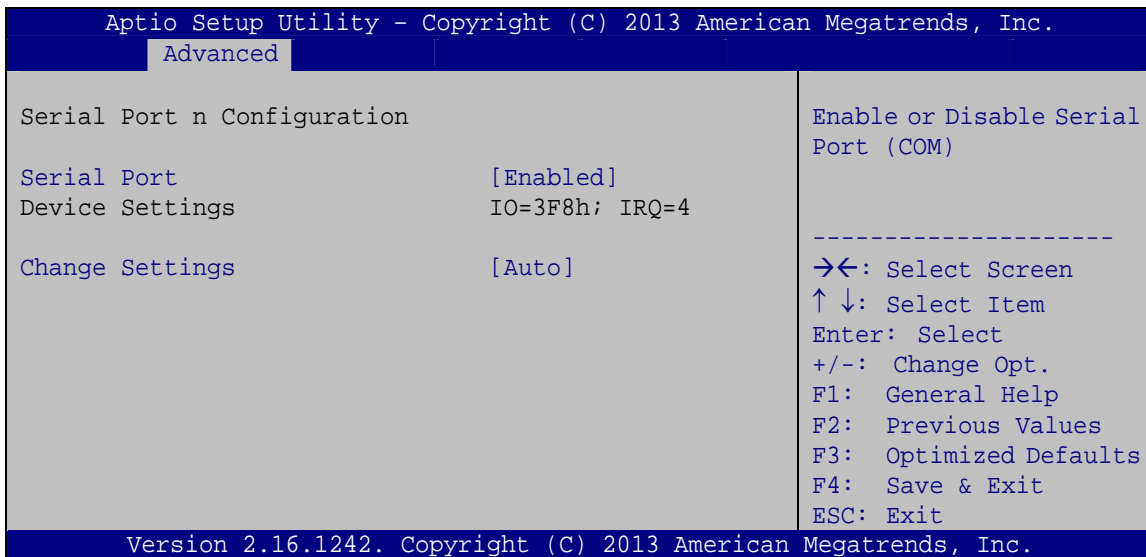

**BIOS Menu 5: Serial Port n Configuration Menu**



## PCISA-BT CPU Card

### 5.3.2.1.1 Serial Port 1 Configuration

#### → Serial Port [Enabled]

Use the **Serial Port** option to enable or disable the serial port.

- **Disabled**                      Disable the serial port
- **Enabled**      **DEFAULT**      Enable the serial port

#### → Change Settings [Auto]

Use the **Change Settings** option to change the serial port IO port address and interrupt address.

- **Auto**              **DEFAULT**      The serial port IO port address and interrupt address are automatically detected.
- **IO=3F8h;**  
**IRQ=4**                      Serial Port I/O port address is 3F8h and the interrupt address is IRQ4
- **IO=3F8h;**  
**IRQ=3, 4**                      Serial Port I/O port address is 3F8h and the interrupt address is IRQ3, 4
- **IO=2F8h;**  
**IRQ=3, 4**                      Serial Port I/O port address is 2F8h and the interrupt address is IRQ3, 4
- **IO=3E8h;**  
**IRQ=3, 4**                      Serial Port I/O port address is 3E8h and the interrupt address is IRQ3, 4
- **IO=2E8h;**  
**IRQ=3, 4**                      Serial Port I/O port address is 2E8h and the interrupt address is IRQ3, 4

### 5.3.2.1.2 Serial Port 2 Configuration

#### → Serial Port [Enabled]

Use the **Serial Port** option to enable or disable the serial port.

- **Disabled**                      Disable the serial port
- **Enabled**      **DEFAULT**      Enable the serial port

→ **Change Settings [Auto]**

Use the **Change Settings** option to change the serial port IO port address and interrupt address.

- **Auto**                    **DEFAULT**                    The serial port IO port address and interrupt address are automatically detected.
- **IO=2F8h;**  
**IRQ=3**                    Serial Port I/O port address is 2F8h and the interrupt address is IRQ3
- **IO=3F8h;**  
**IRQ=3, 4**                    Serial Port I/O port address is 3F8h and the interrupt address is IRQ3, 4
- **IO=2F8h;**  
**IRQ=3, 4**                    Serial Port I/O port address is 2F8h and the interrupt address is IRQ3, 4
- **IO=3E8h;**  
**IRQ=3, 4**                    Serial Port I/O port address is 3E8h and the interrupt address is IRQ3, 4
- **IO=2E8h;**  
**IRQ=3, 4**                    Serial Port I/O port address is 2E8h and the interrupt address is IRQ3, 4

**5.3.2.1.3 Serial Port 3 Configuration**

→ **Serial Port [Enabled]**

Use the **Serial Port** option to enable or disable the serial port.

- **Disabled**                    Disable the serial port
- **Enabled**                    **DEFAULT**                    Enable the serial port

→ **Change Settings [Auto]**

Use the **Change Settings** option to change the serial port IO port address and interrupt address.

- **Auto**                    **DEFAULT**                    The serial port IO port address and interrupt address are automatically detected.

## PCISA-BT CPU Card

- ➔ **IO=3E8h;**  
**IRQ=10**                      Serial Port I/O port address is 3E8h and the interrupt address is IRQ10
- ➔ **IO=3F8h;**  
**IRQ=10, 11**                  Serial Port I/O port address is 3F8h and the interrupt address is IRQ10, 11
- ➔ **IO=2F8h;**  
**IRQ=10, 11**                  Serial Port I/O port address is 2F8h and the interrupt address is IRQ10, 11
- ➔ **IO=3E8h;**  
**IRQ=10, 11**                  Serial Port I/O port address is 3E8h and the interrupt address is IRQ10, 11
- ➔ **IO=2E8h;**  
**IRQ=10, 11**                  Serial Port I/O port address is 2E8h and the interrupt address is IRQ10, 11
- ➔ **IO=2E0h;**  
**IRQ=10, 11**                  Serial Port I/O port address is 2E0h and the interrupt address is IRQ10, 11

### 5.3.2.1.4 Serial Port 4 Configuration

#### ➔ Serial Port [Enabled]

Use the **Serial Port** option to enable or disable the serial port.

- ➔ **Disabled**                      Disable the serial port
- ➔ **Enabled      DEFAULT**      Enable the serial port

#### ➔ Change Settings [Auto]

Use the **Change Settings** option to change the serial port IO port address and interrupt address.

- ➔ **Auto              DEFAULT**      The serial port IO port address and interrupt address are automatically detected.
- ➔ **IO=2E8h;**  
**IRQ=10**                      Serial Port I/O port address is 2E8h and the interrupt address is IRQ10
- ➔ **IO=2E8h;**  
**IRQ=10, 11**                  Serial Port I/O port address is 2E8h and the interrupt address is IRQ10, 11

- ➔ **IO=2D0h;**  
**IRQ=10, 11**                      Serial Port I/O port address is 2D0h and the interrupt address is IRQ10, 11
- ➔ **IO=2D8h;**  
**IRQ=10, 11**                      Serial Port I/O port address is 2D8h and the interrupt address is IRQ10, 11

➔ **Device Mode [RS422/485]**

The serial port 4 is set to RS-422/485 mode.

**5.3.2.1.5 Serial Port 5 Configuration**

➔ **Serial Port [Enabled]**

Use the **Serial Port** option to enable or disable the serial port.

- ➔ **Disabled**                      Disable the serial port
- ➔ **Enabled      DEFAULT**      Enable the serial port

➔ **Change Settings [Auto]**

Use the **Change Settings** option to change the serial port IO port address and interrupt address.

- ➔ **Auto              DEFAULT**      The serial port IO port address and interrupt address are automatically detected.
- ➔ **IO=2C0h;**  
**IRQ=11**                      Serial Port I/O port address is 2C0h and the interrupt address is IRQ11
- ➔ **IO=2C0h;**  
**IRQ=10, 11**                      Serial Port I/O port address is 2C0h and the interrupt address is IRQ10, 11
- ➔ **IO=2C8h;**  
**IRQ=10, 11**                      Serial Port I/O port address is 2C8h and the interrupt address is IRQ10, 11
- ➔ **IO=2D0h;**  
**IRQ=10, 11**                      Serial Port I/O port address is 2D0h and the interrupt address is IRQ10, 11

## PCISA-BT CPU Card

- ➔ **IO=2D8h;**  
**IRQ=10, 11**      Serial Port I/O port address is 2D8h and the interrupt address is IRQ10, 11
- ➔ **IO=2E0h;**  
**IRQ=10, 11**      Serial Port I/O port address is 2E0h and the interrupt address is IRQ10, 11
- ➔ **IO=2E8h;**  
**IRQ=10, 11**      Serial Port I/O port address is 2E8h and the interrupt address is IRQ10, 11

### 5.3.2.1.6 Serial Port 6 Configuration

#### ➔ Serial Port [Enabled]

Use the **Serial Port** option to enable or disable the serial port.

- ➔ **Disabled**      Disable the serial port
- ➔ **Enabled**      **DEFAULT**      Enable the serial port

#### ➔ Change Settings [Auto]

Use the **Change Settings** option to change the serial port IO port address and interrupt address.

- ➔ **Auto**      **DEFAULT**      The serial port IO port address and interrupt address are automatically detected.
- ➔ **IO=2D8h;**  
**IRQ=10**      Serial Port I/O port address is 2D8h and the interrupt address is IRQ10
- ➔ **IO=2C0h;**  
**IRQ=10, 11**      Serial Port I/O port address is 2C0h and the interrupt address is IRQ10, 11
- ➔ **IO=2C8h;**  
**IRQ=10, 11**      Serial Port I/O port address is 2C8h and the interrupt address is IRQ10, 11
- ➔ **IO=2D0h;**  
**IRQ=10, 11**      Serial Port I/O port address is 2D0h and the interrupt address is IRQ10, 11
- ➔ **IO=2D8h;**  
**IRQ=10, 11**      Serial Port I/O port address is 2D8h and the interrupt address is IRQ10, 11



- ➔ **IO=2E0h;**                      Serial Port I/O port address is 2E0h and the interrupt address is IRQ10, 11  
     **IRQ=10, 11**
- ➔ **IO=2E8h;**                      Serial Port I/O port address is 2E8h and the interrupt address is IRQ10, 11  
     **IRQ=10, 11**

### 5.3.2.2 IrDA Configuration

Use the **IrDA Configuration** menu (**BIOS Menu 6**) to configure the infrared port.

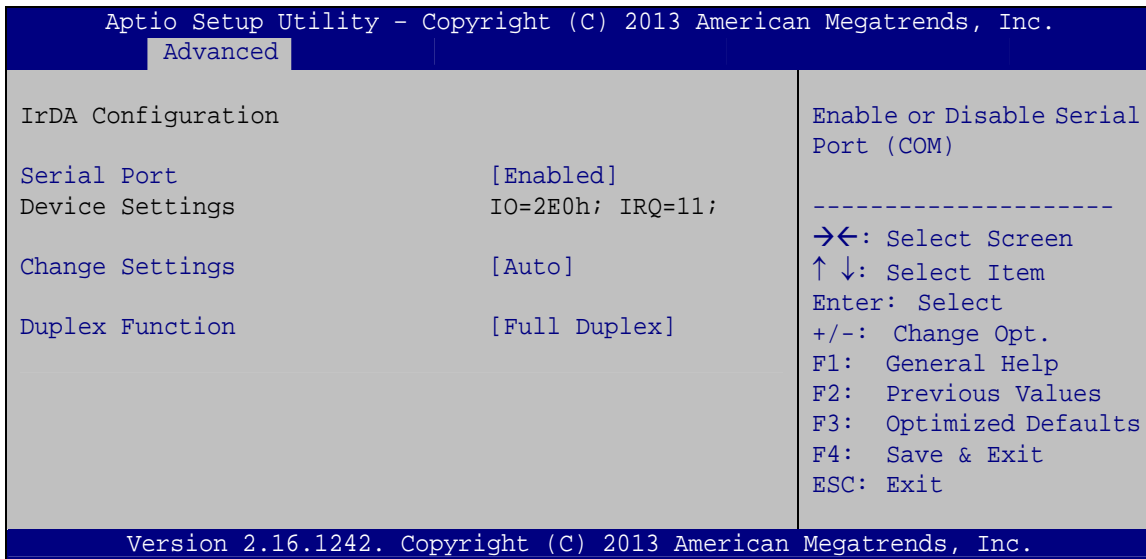

#### BIOS Menu 6: IrDA Configuration Menu

##### ➔ **Serial Port [Enabled]**

Use the **Serial Port** option to enable or disable the IrDA function.

- ➔ **Disabled**                      Disable the IrDA function
- ➔ **Enabled      DEFAULT**        Enable the IrDA function

##### ➔ **Change Settings [Auto]**

Use the **Change Settings** option to change the serial port IO address and interrupt address.

## PCISA-BT CPU Card

- |   |                                |                |   |
|---|--------------------------------|----------------|---|
| ➔ | <b>Auto</b>                    | <b>DEFAULT</b> | The serial port IO port address and interrupt address are automatically detected. |
| ➔ | <b>IO=2E0h;<br/>IRQ=11</b>     |                | Serial Port I/O port address is 2E0h and the interrupt address is IRQ11           |
| ➔ | <b>IO=3F8h;<br/>IRQ=10, 11</b> |                | Serial Port I/O port address is 3F8h and the interrupt address is IRQ10, 11       |
| ➔ | <b>IO=2F8h;<br/>IRQ=10, 11</b> |                | Serial Port I/O port address is 2F8h and the interrupt address is IRQ10, 11       |
| ➔ | <b>IO=3E8h;<br/>IRQ=10, 11</b> |                | Serial Port I/O port address is 3E8h and the interrupt address is IRQ10, 11       |
| ➔ | <b>IO=2E8h;<br/>IRQ=10, 11</b> |                | Serial Port I/O port address is 2E8h and the interrupt address is IRQ10, 11       |
| ➔ | <b>IO=2D0h;<br/>IRQ=10, 11</b> |                | Serial Port I/O port address is 2D0h and the interrupt address is IRQ10, 11       |
| ➔ | <b>IO=2E0h;<br/>IRQ=10, 11</b> |                | Serial Port I/O port address is 2E0h and the interrupt address is IRQ10, 11       |

### ➔ Duplex Function [Full Duplex]

Use the **Duplex Function** option to select the IR data transmission mode.

- |   |                    |                |   |
|---|--------------------|----------------|---|
| ➔ | <b>Full Duplex</b> | <b>DEFAULT</b> | The communication channels are used to send and receive the data in both directions at the same time.                                       |
| ➔ | <b>Half Duplex</b> |                | Transmission signals are sent in both directions, but one direction at a time so half duplex lines can alternatively send and receive data. |

### 5.3.2.3 Parallel Port Configuration

Use the **Parallel Port Configuration** menu (**BIOS Menu 7**) to configure the serial port n.

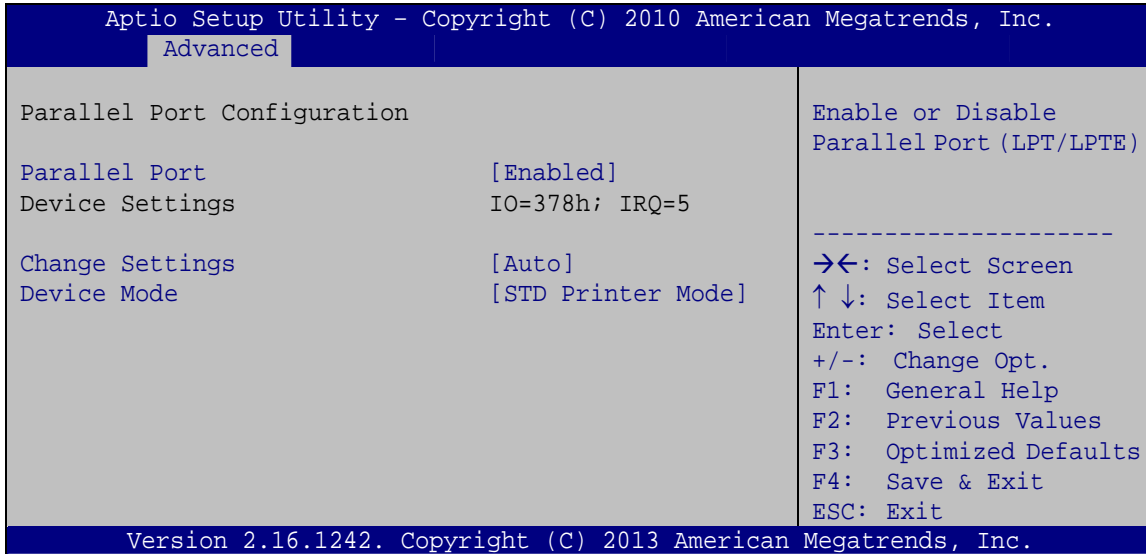

#### BIOS Menu 7: Parallel Port Configuration Menu

##### → Parallel Port [Enabled]

Use the **Parallel Port** option to enable or disable the parallel port.

- **Disabled**                      Disable the parallel port
- **Enabled      DEFAULT**      Enable the parallel port

##### → Change Settings [Auto]

Use the **Change Settings** option to change the parallel port IO port address and interrupt address.

- **Auto              DEFAULT**      The parallel port IO port address and interrupt address are automatically detected.
- **IO=378h;                      Parallel Port I/O port address is 378h and the  
IRQ=5                              interrupt address is IRQ5.**

## PCISA-BT CPU Card

- ➔ **IO=378h;**  
**IRQ=5, 6,**  
**7, 9, 10, 11,**  
**12**  
Parallel Port I/O port address is 378h and the interrupt address is IRQ5, 6, 7, 9, 10, 11, 12
- ➔ **IO=278h;**  
**IRQ=5, 6,**  
**7, 9, 10, 11,**  
**12**  
Parallel Port I/O port address is 278h and the interrupt address is IRQ5, 6, 7, 9, 10, 11, 12
- ➔ **IO=3BCh;**  
**IRQ=5, 6,**  
**7, 9, 10, 11,**  
**12**  
Parallel Port I/O port address is 3BCh and the interrupt address is IRQ5, 6, 7, 9, 10, 11, 12.

### ➔ **Device Mode [STD Printer Mode]**

Use the **Device Mode** option to select the mode the parallel port operates in. Configuration options are listed below.

- STD Printer Mode **Default**
- SPP Mode
- EPP-1.9 and SPP Mode
- EPP-1.7 and SPP Mode
- ECP Mode
- ECP and EPP 1.9 Mode
- ECP and EPP 1.7 Mode

### 5.3.3 iWDD H/W Monitor

The **iWDD H/W Monitor** menu (**BIOS Menu 8**) contains the fan configuration submenu, and displays operating temperature, fan speeds and system voltages..

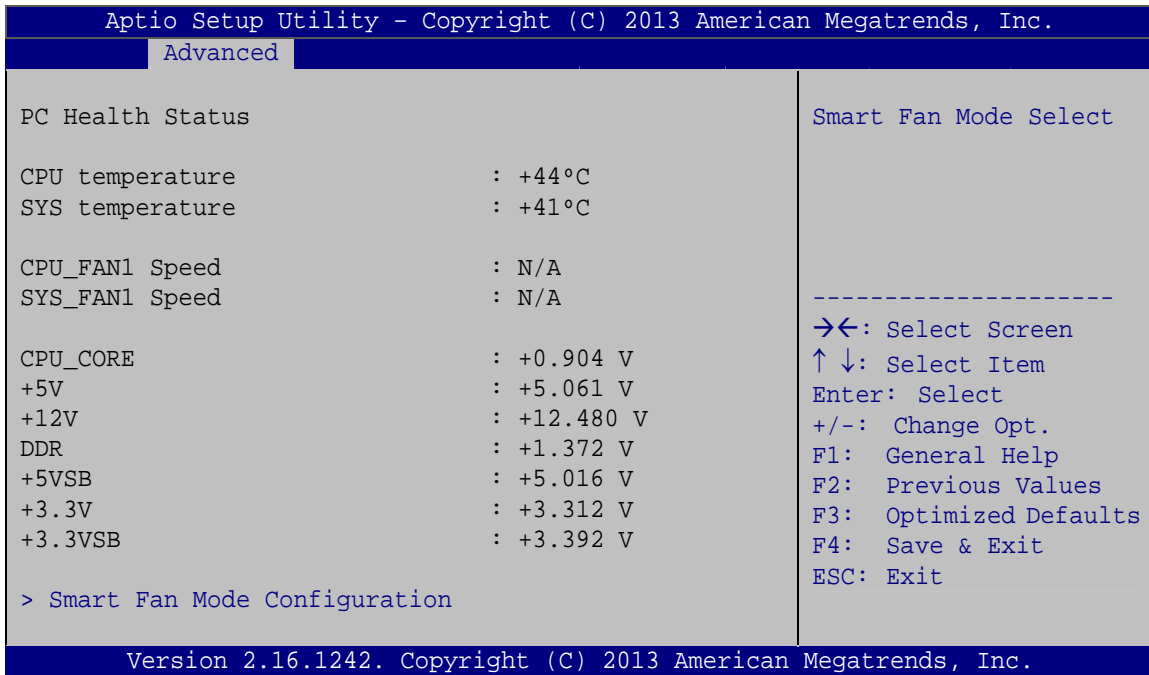

#### BIOS Menu 8: iWDD H/W Monitor

##### ➔ PC Health Status

The following system parameters and values are shown. The system parameters that are monitored are:

- System Temperatures:
  - CPU Temperature
  - System Temperature
- Fan Speeds:
  - CPU Fan Speed
  - System Fan Speed
- Voltages:
  - CPU\_CORE
  - +5V
  - +12V
  - DDR



## PCISA-BT CPU Card

- +5VSB
- +3.3V
- +3.3VSB

### 5.3.3.1 Smart Fan Mode Configuration

Use the **Smart Fan Mode Configuration** submenu (**BIOS Menu 9**) to configure fan speed settings.

```

Aptio Setup Utility - Copyright (C) 2013 American Megatrends, Inc.
  Advanced
Smart Fan Mode Configuration
CPU_FAN1 Smart Fan Control      [Auto Mode]
Auto mode fan start temperature 50
Auto mode fan off temperature   40
Auto mode fan start PWM         30
Auto mode fan slope PWM        1
SYS_FAN1 Smart Fan Control      [Auto Mode]
Auto mode fan start temperature  50
Auto mode fan off temperature   40
Auto mode fan start PWM         30
Auto mode fan slope PWM        1
Smart Fan Mode Select
-----
-><: Select Screen
↑ ↓: Select Item
Enter: Select
+/-: Change Opt.
F1:  General Help
F2:  Previous Values
F3:  Optimized Defaults
F4:  Save & Exit
ESC: Exit
Version 2.16.1242. Copyright (C) 2013 American Megatrends, Inc.
  
```

#### BIOS Menu 9: Smart Fan Mode Configuration

##### ➔ CPU\_FAN1 Smart Fan Control/SYS\_FAN1 Smart Fan Control [Auto Mode]

Use the **CPU\_FAN1 Smart Fan Control/SYS\_FAN1 Smart Fan Control** option to configure the CPU/System Smart Fan.

- ➔ **Auto Mode**      **DEFAULT**      The fan adjusts its speed using Auto Mode settings.
- ➔ **Manual Mode**                      The fan spins at the speed set in Manual Mode settings.

##### ➔ Auto mode fan start/off temperature

Use the + or – key to change the **Auto mode fan start/off temperature** value. Enter a decimal number between 1 and 100.

➔ **Auto mode fan start PWM**

Use the + or – key to change the **Auto mode fan start PWM** value. Enter a decimal number between 1 and 100.

➔ **Auto mode fan slope PWM**

Use the + or – key to change the **Auto mode fan slope PWM** value. Enter a decimal number between 1 and 8.

### 5.3.4 RTC Wake Settings

The **RTC Wake Settings** menu (**BIOS Menu 10**) enables the system to wake at the specified time.

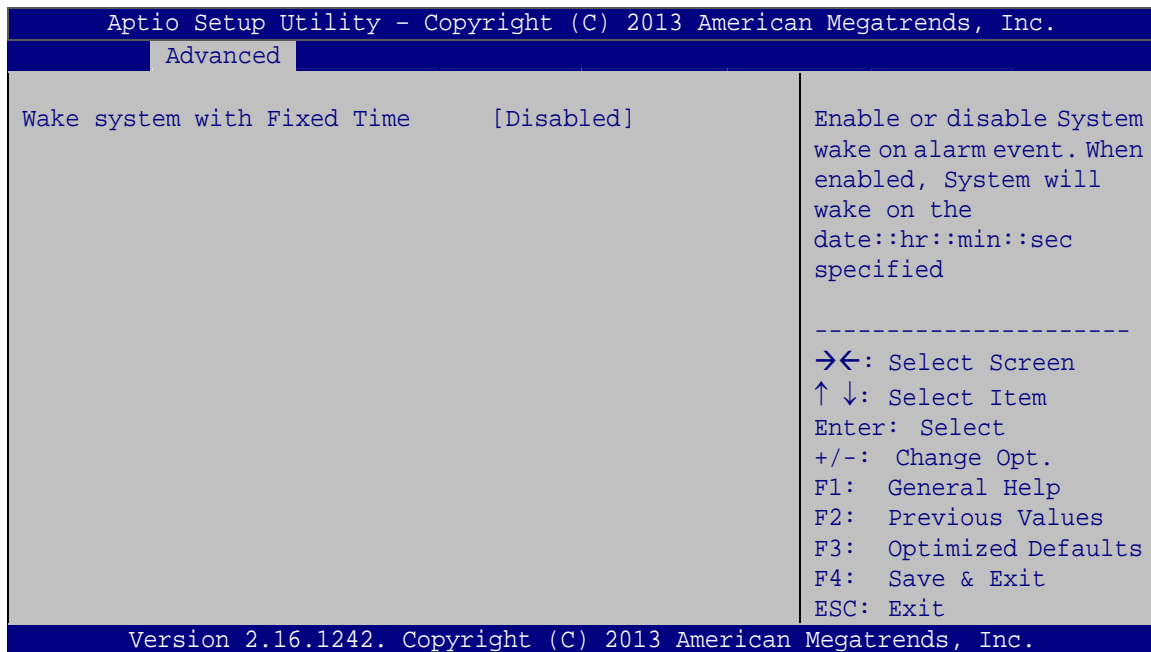

#### BIOS Menu 10: RTC Wake Settings

➔ **Wake system with Fixed Time [Disabled]**

Use the **Wake system with Fixed Time** option to enable or disable the system wake on alarm event.

- ➔ **Disabled**      **DEFAULT**      The real time clock (RTC) cannot generate a wake event.

## PCISA-BT CPU Card

### → Enabled

If selected, the **Wake up every day** option appears allowing you to enable to disable the system to wake every day at the specified time. Besides, the following options appear with values that can be selected:

Wake up date

Wake up hour

Wake up minute

Wake up second

After setting the alarm, the computer turns itself on from a suspend state when the alarm goes off.

### 5.3.5 Serial Port Console Redirection

The **Serial Port Console Redirection** menu (**BIOS Menu 11**) allows the console redirection options to be configured. Console redirection allows users to maintain a system remotely by re-directing keyboard input and text output through the serial port.

```

Aptio Setup Utility - Copyright (C) 2013 American Megatrends, Inc.
  Advanced
-----
COM1
  Console Redirection          [Disabled]
  Console Redirection Settings
COM2
  Console Redirection          [Disabled]
  Console Redirection Settings
COM3
  Console Redirection          [Disabled]
  Console Redirection Settings
-----
  Console Redirection
  Enable or Disable
-----
  →←: Select Screen
  ↑ ↓: Select Item
  Enter: Select
  +/-: Change Opt.
  F1: General Help
  F2: Previous Values
  F3: Optimized Defaults
  F4: Save & Exit
  ESC: Exit
-----
Version 2.16.1242. Copyright (C) 2013 American Megatrends, Inc.
  
```

**BIOS Menu 11: Serial Port Console Redirection**

→ **Console Redirection [Disabled]**

Use **Console Redirection** option to enable or disable the console redirection function.

- **Disabled**      **DEFAULT**      Disabled the console redirection function
- **Enabled**                      Enabled the console redirection function

The following options are available in the **Console Redirection Settings** submenu when the **Console Redirection** option is enabled.

→ **Terminal Type [ANSI]**

Use the **Terminal Type** option to specify the remote terminal type.

- **VT100**                      The target terminal type is VT100
- **VT100+**                      The target terminal type is VT100+
- **VT-UTF8**                      The target terminal type is VT-UTF8
- **ANSI**              **DEFAULT**      The target terminal type is ANSI

→ **Bits per second [115200]**

Use the **Bits per second** option to specify the serial port transmission speed. The speed must match the other side. Long or noisy lines may require lower speeds.

- **9600**                      Sets the serial port transmission speed at 9600.
- **19200**                      Sets the serial port transmission speed at 19200.
- **38400**                      Sets the serial port transmission speed at 38400.
- **57600**                      Sets the serial port transmission speed at 57600.
- **115200**              **DEFAULT**      Sets the serial port transmission speed at 115200.

→ **Data Bits [8]**

Use the **Data Bits** option to specify the number of data bits.

- **7**                      Sets the data bits at 7.
- **8**                      **DEFAULT**      Sets the data bits at 8.

## PCISA-BT CPU Card

### → Parity [None]

Use the **Parity** option to specify the parity bit that can be sent with the data bits for detecting the transmission errors.

- |   |              |                |   |
|---|--------------|----------------|---|
| → | <b>None</b>  | <b>DEFAULT</b> | No parity bit is sent with the data bits.                                 |
| → | <b>Even</b>  |                | The parity bit is 0 if the number of ones in the data bits is even.       |
| → | <b>Odd</b>   |                | The parity bit is 0 if the number of ones in the data bits is odd.        |
| → | <b>Mark</b>  |                | The parity bit is always 1. This option does not provide error detection. |
| → | <b>Space</b> |                | The parity bit is always 0. This option does not provide error detection. |

### → Stop Bits [1]

Use the **Stop Bits** option to specify the number of stop bits used to indicate the end of a serial data packet. Communication with slow devices may require more than 1 stop bit.

- |   |          |                |                                    |
|---|----------|----------------|------------------------------------|
| → | <b>1</b> | <b>DEFAULT</b> | Sets the number of stop bits at 1. |
| → | <b>2</b> |                | Sets the number of stop bits at 2. |



### 5.3.6 iEi Feature

Use the **iEi Feature** menu (**BIOS Menu 12**) to configure One Key Recovery function.

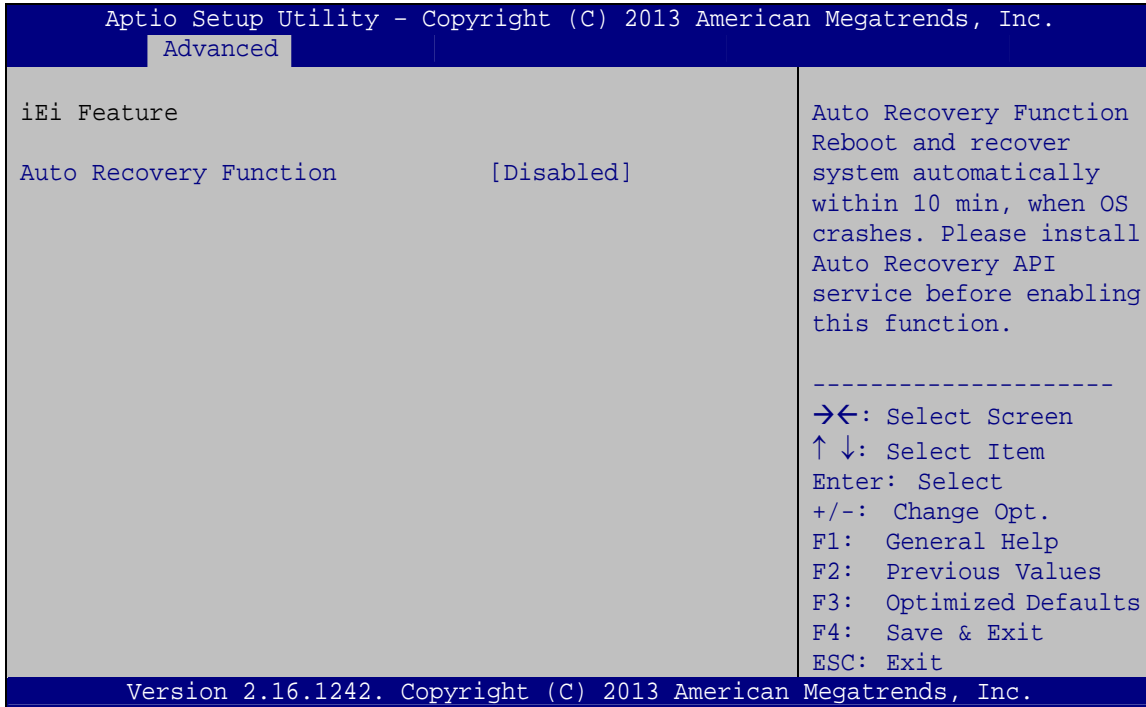

#### BIOS Menu 12: iEi Feature

##### → Auto Recovery Function [Disabled]

Use the **Auto Recovery Function** BIOS option to enable or disable the auto recovery function of the IEI One Key Recovery.

- **Disabled**      **DEFAULT**      Auto recovery function disabled
- **Enabled**      Auto recovery function enabled

## PCISA-BT CPU Card

### 5.3.7 CPU Configuration

Use the **CPU Configuration** menu (**BIOS Menu 13**) to view detailed CPU specifications or enable the Intel Virtualization Technology.

```

Aptio Setup Utility - Copyright (C) 2013 American Megatrends, Inc.
  Advanced
CPU Information
Intel(R) Atom(TM) CPU E3845 @ 1.91GHz
CPU Signature           30679
Microcode Patch        901
Max CPU Speed          1910 MHz
Min CPU Speed          500 MHz
Processor Cores        4
Intel HT Technology     Not Supported
Intel VT-x Technology  Supported

L1 Data Cache          24 kB x 4
L1 Code Cache          32 kB x 4
L2 Cache               1024 kB x 2
L3 Cache               Not Present
64-bit                 Supported

Intel Virtualization Technology [Disabled]
EIST                   [Enabled]

When enabled, a VMM can utilize the additional hardware capabilities provided by Vanderpool Technology.

-----
-><: Select Screen
↑↓: Select Item
Enter: Select
+/-: Change Opt.
F1: General Help
F2: Previous Values
F3: Optimized Defaults
F4: Save & Exit
ESC: Exit

Version 2.16.1242. Copyright (C) 2013 American Megatrends, Inc.
  
```

#### BIOS Menu 13: CPU Configuration

##### → Intel Virtualization Technology [Disabled]

Use the **Intel Virtualization Technology** option to enable or disable virtualization on the system. When combined with third party software, Intel® Virtualization technology allows several OSs to run on the same system at the same time.

- **Disabled**                      **DEFAULT**      Disables Intel Virtualization Technology.
- **Enabled**    Enables Intel Virtualization Technology.

##### → EIST [Enabled]

Use the **EIST** option to enable or disable the Enhanced Intel® SpeedStep Technology (EIST).



## PCISA-BT CPU Card

### 5.3.9 Trusted Computing

Use the **Trusted Computing** menu (**BIOS Menu 15**) to configure settings related to the Trusted Computing Group (TCG) Trusted Platform Module (TPM).

```

Aptio Setup Utility - Copyright (C) 2013 American Megatrends, Inc.
  Advanced
-----
Configuration
Security Device Support          [Disabled]
Current Status Information
NO Security Device Found
-----
Enables or Disables BIOS
support for security
device. O.S. will not
show Security Device.
TCG EFI protocol and
INT1A interface will not
be available.

-----
-><: Select Screen
↑↓: Select Item
Enter: Select
+/-: Change Opt.
F1:  General Help
F2:  Previous Values
F3:  Optimized Defaults
F4:  Save & Exit
ESC: Exit

Version 2.16.1242. Copyright (C) 2013 American Megatrends, Inc.
  
```

#### BIOS Menu 15: Trusted Computing

##### ➔ Security Device Support [Disabled]

Use the **Security Device Support** option to configure support for the TPM.

- ➔ **Disabled**    **DEFAULT**    TPM support is disabled.
- ➔ **Enabled**                    TPM support is enabled.

### 5.3.10 USB Configuration

Use the **USB Configuration** menu (**BIOS Menu 16**) to read USB configuration information and configure the USB settings.

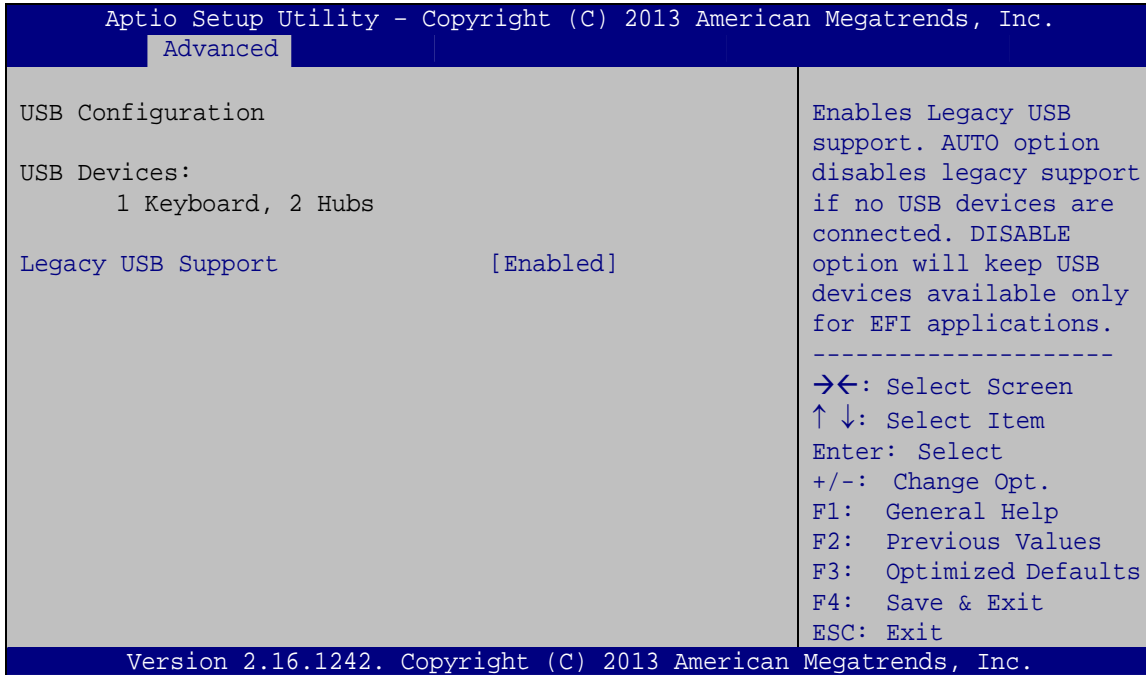

#### BIOS Menu 16: USB Configuration

##### → USB Devices

The **USB Devices** field lists the USB devices that are enabled on the system

##### → Legacy USB Support [Enabled]

Use the **Legacy USB Support** BIOS option to enable USB mouse and USB keyboard support. Normally if this option is not enabled, any attached USB mouse or USB keyboard does not become available until a USB compatible operating system is fully booted with all USB drivers loaded. When this option is enabled, any attached USB mouse or USB keyboard can control the system even when there is no USB driver loaded onto the system.

- **Enabled**      **DEFAULT**      Legacy USB support enabled
- **Disabled**                      Legacy USB support disabled
- **Auto**                              Legacy USB support disabled if no USB devices are connected



## PCISA-BT CPU Card

### 5.4 Chipset

Use the **Chipset** menu (**BIOS Menu 17**) to access the PCH IO and System Agent (SA) configuration menus.



#### **WARNING!**

Setting the wrong values for the Chipset BIOS selections in the Chipset BIOS menu may cause the system to malfunction.

```

Aptio Setup Utility - Copyright (C) 2013 American Megatrends, Inc.
Main   Advanced  Chipset  Security  Boot   Save & Exit
-----
> North Bridge
> South Bridge

North Bridge Parameters
-----
-><: Select Screen
↑↓: Select Item
Enter: Select
+/-: Change Opt.
F1: General Help
F2: Previous Values
F3: Optimized Defaults
F4: Save & Exit
ESC: Exit

Version 2.16.1242. Copyright (C) 2013 American Megatrends, Inc.
    
```

**BIOS Menu 17: Chipset**

### 5.4.1 North Bridge

Use the **North Bridge** menu (**BIOS Menu 18**) to configure the north bridge parameters.

```

Aptio Setup Utility - Copyright (C) 2013 American Megatrends, Inc.
  Chipset
> Intel IGD Configuration          Configure Intel IGD
Memory Information                Settings.
Total Memory                      2048 MB (LPDDR3)
DIMM1                             2048 MB (LPDDR3)
-----
-><: Select Screen
↑↓: Select Item
Enter: Select
+/-: Change Opt.
F1:  General Help
F2:  Previous Values
F3:  Optimized Defaults
F4:  Save & Exit
ESC: Exit
Version 2.16.1242. Copyright (C) 2013 American Megatrends, Inc.
  
```

**BIOS Menu 18: North Bridge**

#### 5.4.1.1 Intel IGD Configuration

Use the **Intel IGD Configuration** submenu (**BIOS Menu 19**) to configure the graphics settings.

```

Aptio Setup Utility - Copyright (C) 2013 American Megatrends, Inc.
  Chipset
Intel IGD Configuration          Select which of IGD/PCI
Primary Display                  Graphics device should
DVMT Pre-Allocated              [Auto]                be Primary Display.
DVMT Total Gfx Mem              [256M]
Primary IGFX Boot Display        [Max]
                                  -----
                                  -><: Select Screen
                                  ↑↓: Select Item
                                  Enter: Select
                                  +/-: Change Opt.
                                  F1:  General Help
                                  F2:  Previous Values
                                  F3:  Optimized Defaults
                                  F4:  Save & Exit
                                  ESC: Exit
Version 2.16.1242. Copyright (C) 2013 American Megatrends, Inc.
  
```

**BIOS Menu 19: Intel IGD Configuration**

## PCISA-BT CPU Card

### → Primary Display [Auto]

Use the **Primary Display** option to select the display device used by the system when it boots. Configuration options are listed below.

- Auto                   **DEFAULT**
- IGD
- PCI

### → DVMT Pre-Allocated [256M]

Use the **DVMT Pre-Allocated** option to specify the amount of system memory that can be used by the internal graphics device.

- 64M                                   64 MB of memory used by internal graphics device
- 128M                                   128 MB of memory used by internal graphics device
- 256M                               **DEFAULT**   256 MB of memory used by internal graphics device
- 512M                                   512 MB of memory used by internal graphics device

### → DVMT Total Gfx Mem [Max]

Use the **DVMT Total Gfx Mem** option to specify the maximum amount of memory that can be allocated as graphics memory. Configuration options are listed below.

- 128MB
- 256MB
- Max                   **DEFAULT**

### → Primary IGFX Boot Display [VBIOS Default]

Use the **Primary IGFX Boot Display** option to select the display device used by the system when it boots. Configuration options are listed below.

- VBIOS Default       **DEFAULT**

- CRT
- DP1
- LVDS (Optional)

### 5.4.2 South Bridge

Use the **South Bridge** menu (**BIOS Menu 20**) to configure the south bridge parameters.

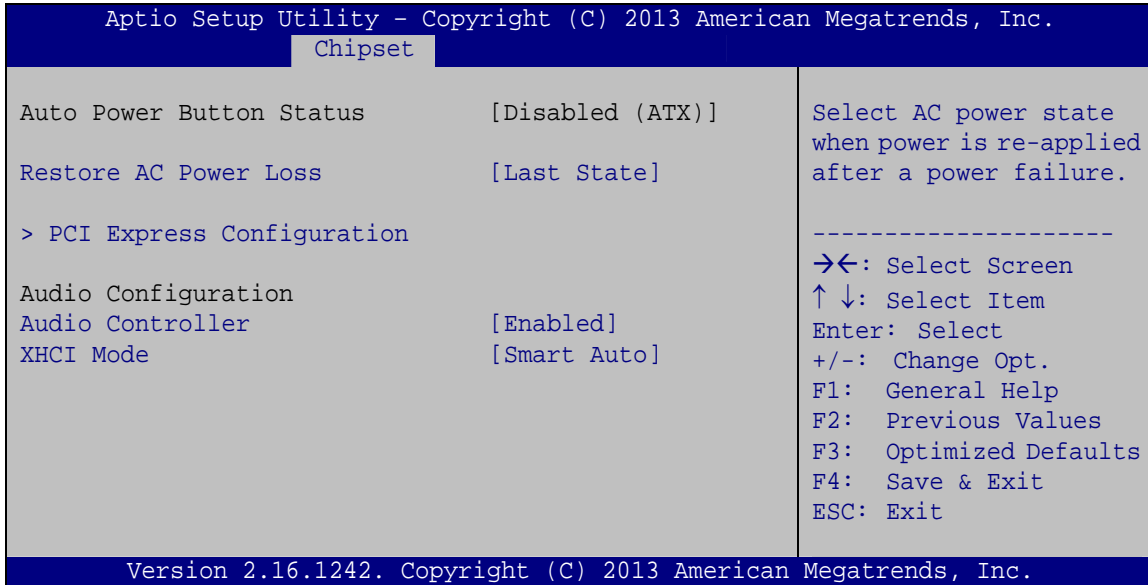

#### BIOS Menu 20: South Bridge

##### → Restore on AC Power Loss [Last State]

Use the **Restore on AC Power Loss** BIOS option to specify what state the system returns to if there is a sudden loss of power to the system.

- **Power Off**                      The system remains turned off
- **Power On**                        The system turns on
- **Last State    DEFAULT**        The system returns to its previous state. If it was on, it turns itself on. If it was off, it remains off.

##### → Audio Controller [Enabled]

Use the **Audio Controller** BIOS option to enable or disable the High Definition Audio controller.

## PCISA-BT CPU Card

- ➔ **Disabled**                      The High Definition Audio controller is disabled.
- ➔ **Enabled**      **DEFAULT**      The High Definition Audio controller is enabled.

### ➔ **XHCI Mode [Smart Auto]**

Use the **XHCI Mode** BIOS option to configure the USB xHCI (USB 3.0) controller.

- ➔ **Enabled**                      Enable the xHCI controller. USB 3.0 ports behave as USB 3.0 ports.
- ➔ **Smart**      **DEFAULT**      Allow the use of USB 3.0 devices prior to OS boot.  
**Auto**                      USB 3.0 ports function as USB 3.0 ports even during a reboot.

### 5.4.2.1 PCI Express Configuration

Use the **PCI Express Configuration** submenu (**BIOS Menu 21**) to configure the PCIe Mini slot.

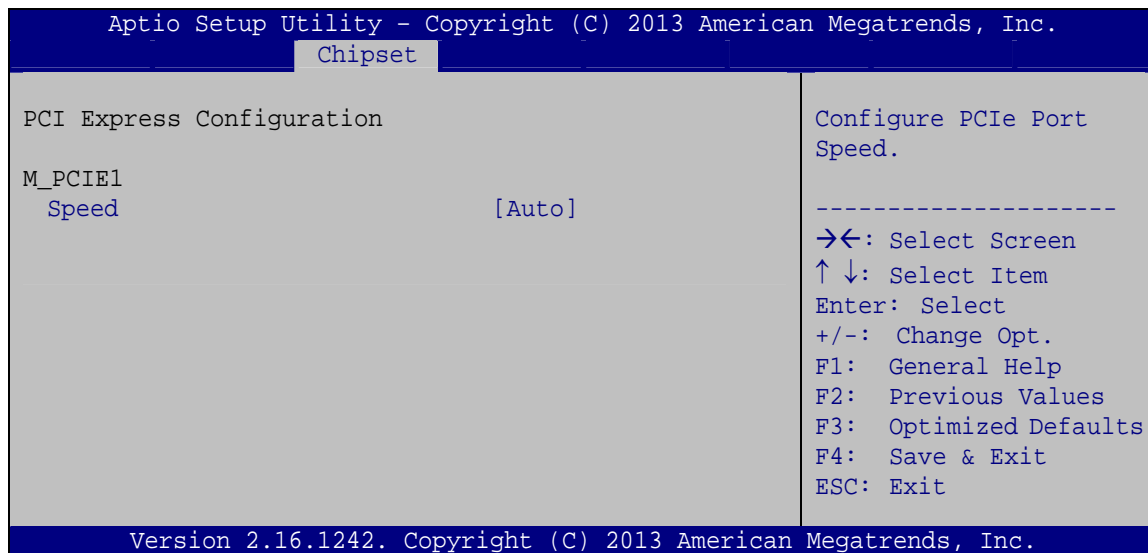

**BIOS Menu 21: PCI Express Configuration**



→ **Speed [Auto]**

Use the **Speed** option to configure the speed of PCIe Mini slot.

- Auto                   **DEFAULT**
- Gen 2
- Gen 1

## 5.5 Security

Use the **Security** menu (**BIOS Menu 22**) to set system and user passwords.

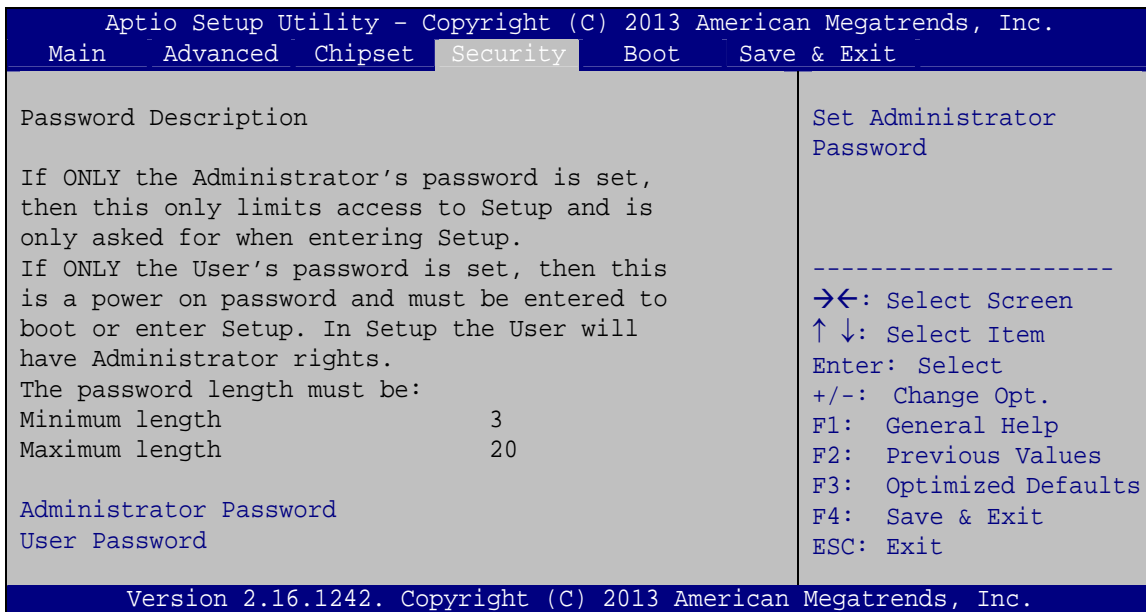

### BIOS Menu 22: Security

→ **Administrator Password**

Use the **Administrator Password** to set or change a administrator password.

→ **User Password**

Use the **User Password** to set or change a user password.

## PCISA-BT CPU Card

### 5.6 Boot

Use the **Boot** menu (**BIOS Menu 23**) to configure system boot options.

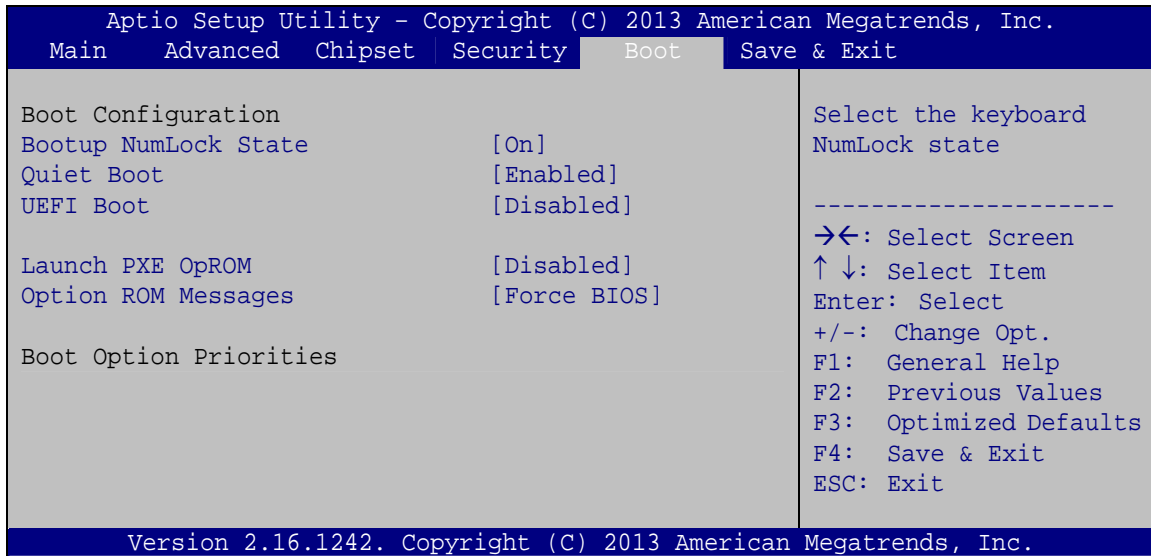

#### BIOS Menu 23: Boot

##### → Bootup NumLock State [On]

Use the **Bootup NumLock State** BIOS option to specify if the number lock setting must be modified during boot up.

- **On**                      **DEFAULT**                      Allows the Number Lock on the keyboard to be enabled automatically when the computer system boots up. This allows the immediate use of the 10-key numeric keypad located on the right side of the keyboard. To confirm this, the Number Lock LED light on the keyboard is lit.
- **Off**                                      Does not enable the keyboard Number Lock automatically. To use the 10-keys on the keyboard, press the Number Lock key located on the upper left-hand corner of the 10-key pad. The Number Lock LED on the keyboard lights up when the Number Lock is engaged.

→ **Quiet Boot [Enabled]**

Use the **Quiet Boot** BIOS option to select the screen display when the system boots.

- **Disabled** Normal POST messages displayed
- **Enabled**     **DEFAULT**    OEM Logo displayed instead of POST messages

→ **UEFI Boot [Disabled]**

Use the **UEFI Boot** option to enable or disable to boot from the UEFI devices.

- **Enabled** Boot from UEFI devices is enabled.
- **Disabled**     **DEFAULT**    Boot from UEFI devices is disabled.

→ **Launch PXE OpROM [Disabled]**

Use the **Launch PXE OpROM** option to enable or disable boot option for legacy network devices.

- **Disabled**     **DEFAULT**    Ignore all PXE Option ROMs
- **Enabled**       Load PXE Option ROMs.

→ **Option ROM Messages [Force BIOS]**

Use the **Option ROM Messages** option to set the Option ROM display mode.

- **Force BIOS**     **DEFAULT**    Sets display mode to force BIOS.
- **Keep Current**       Sets display mode to current.

## PCISA-BT CPU Card

### 5.7 Save & Exit

Use the **Safe & Exit** menu (**BIOS Menu 24**) to load default BIOS values, optimal failsafe values and to save configuration changes.

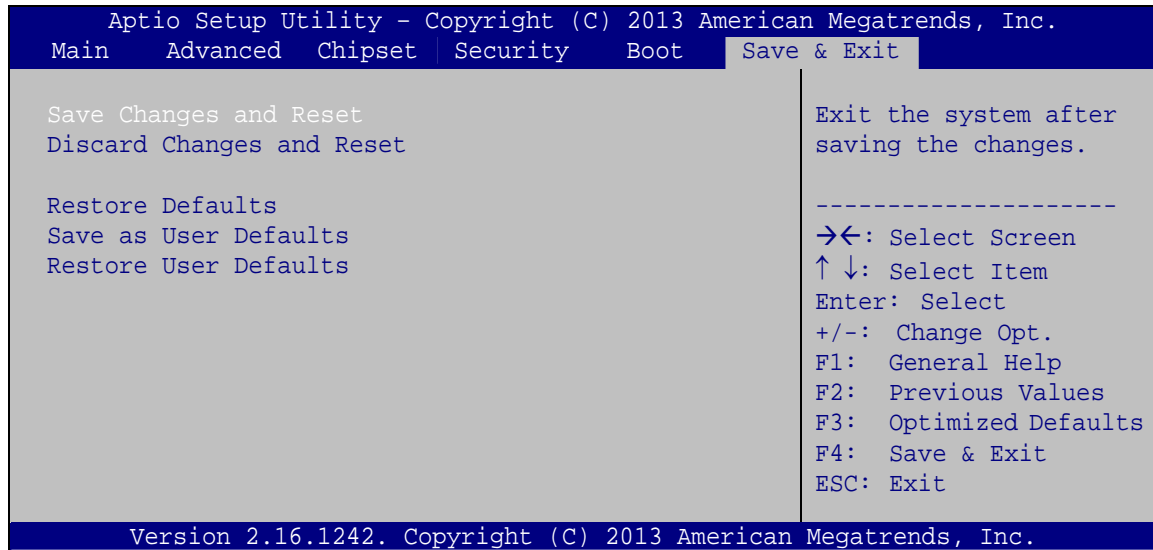

#### BIOS Menu 24: Save & Exit

##### → Save Changes and Reset

Use the **Save Changes and Reset** option to save the changes made to the BIOS options and reset the system.

##### → Discard Changes and Reset

Use the **Discard Changes and Reset** option to exit the system without saving the changes made to the BIOS configuration setup program.

##### → Restore Defaults

Use the **Restore Defaults** option to load the optimal default values for each of the parameters on the Setup menus. **F3 key can be used for this operation.**

##### → Save as User Defaults

Use the **Save as User Defaults** option to save the changes done so far as user defaults.

##### → Restore User Defaults

Use the **Restore User Defaults** option to restore the user defaults to all the setup options.

Chapter

**6**

# Software Drivers

---



## PCISA-BT CPU Card



### NOTE:

The content of the CD may vary throughout the life cycle of the product and is subject to change without prior notice. Visit the IEI website or contact technical support for the latest updates.

## 6.1 Software Installation

All the drivers for the PCISA-BT are on the CD that came with the system. To install the drivers, please follow the steps below.

**Step 1:** Insert the CD into a CD drive connected to the system.



### NOTE:

If the installation program doesn't start automatically:  
Click "Start->My Computer->CD Drive->autorun.exe"

**Step 2:** The driver main menu appears (**Figure 6-1**).



Figure 6-1: Introduction Screen

**Step 3:** Click PCISA-BT.

**Step 4:** A new screen with a list of available drivers appears (**Figure 6-2**).



**Figure 6-2: Available Drivers**

**Step 5:** Install all of the necessary drivers in this menu.

## 6.2 Available Software Drivers

All the drivers for the PCISA-BT are on the utility CD that came with the system. The utility CD contains drivers for Windows 7 and Windows 8 operating systems. Please select the corresponding drivers for the system.

The following drivers can be installed on the **Windows 7** operating system:

- Bay Trail SoC
  - Chipset
  - Graphics
  - I/O driver
  - TXE
  - USB 3.0
- LAN - Intel
- Audio

**NOTE:**

The Intel TXE requires that Microsoft's "Kernel-Mode Driver Framework (KMDF) version 1.11 update for Windows 7" is installed first. If the KMDF is not installed, either error 37 or error 28 may appear on the Intel TXE device in Device Manager.

Click the following link to download the KMDF version 1.11 update for Windows 7:

<http://www.microsoft.com/en-us/download/details.aspx?id=38423>

---

The following drivers can be installed on the **Windows 8** operating system:

- Bay Trail SOC
  - Chipset
  - Graphics
  - I/O driver
  - TXE
- LAN - Intel
- Audio

Appendix

**A**

# Regulatory Compliance

---

**DECLARATION OF CONFORMITY**



This equipment has been tested and found to comply with specifications for CE marking. If the user modifies and/or installs other devices in the equipment, the CE conformity declaration may no longer apply.

**FCC WARNING**



This equipment complies with Part 15 of the FCC Rules. Operation is subject to the following two conditions:

- This device may not cause harmful interference, and
- This device must accept any interference received, including interference that may cause undesired operation.

This equipment has been tested and found to comply with the limits for a Class A digital device, pursuant to part 15 of the FCC Rules. These limits are designed to provide reasonable protection against harmful interference when the equipment is operated in a commercial environment. This equipment generates, uses, and can radiate radio frequency energy and, if not installed and used in accordance with the instruction manual, may cause harmful interference to radio communications. Operation of this equipment in a residential area is likely to cause harmful interference in which case the user will be required to correct the interference at his own expense.



Appendix

**B**

# Product Disposal

---

**CAUTION:**

Risk of explosion if battery is replaced by an incorrect type. Only certified engineers should replace the on-board battery.

Dispose of used batteries according to instructions and local regulations.

---

- Outside the European Union – If you wish to dispose of used electrical and electronic products outside the European Union, please contact your local authority so as to comply with the correct disposal method.
- Within the European Union – The device that produces less waste and is easier to recycle is classified as electronic device in terms of the European Directive 2012/19/EU (WEEE), and must not be disposed of as domestic garbage.

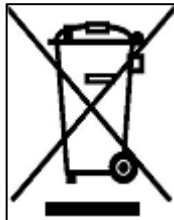

EU-wide legislation, as implemented in each Member State, requires that waste electrical and electronic products carrying the mark (left) must be disposed of separately from normal household waste. This includes monitors and electrical accessories, such as signal cables or power cords. When you need to dispose of your device, please follow the guidance of your local authority, or ask the shop where you purchased the product. The mark on electrical and electronic products only applies to the current European Union Member States.

Please follow the national guidelines for electrical and electronic product disposal.

Appendix

C

# BIOS Options

---

## PCISA-BT CPU Card

Below is a list of BIOS configuration options in the BIOS chapter.

<b>System Date [xx/xx/xx]</b> .....	<b>67</b>
<b>System Time [xx:xx:xx]</b> .....	<b>67</b>
<b>ACPI Sleep State [S3 (Suspend to RAM)]</b> .....	<b>69</b>
<b>Serial Port [Enabled]</b> .....	<b>71</b>
<b>Change Settings [Auto]</b> .....	<b>71</b>
<b>Serial Port [Enabled]</b> .....	<b>71</b>
<b>Change Settings [Auto]</b> .....	<b>72</b>
<b>Serial Port [Enabled]</b> .....	<b>72</b>
<b>Change Settings [Auto]</b> .....	<b>72</b>
<b>Serial Port [Enabled]</b> .....	<b>73</b>
<b>Change Settings [Auto]</b> .....	<b>73</b>
<b>Device Mode [RS422/485]</b> .....	<b>74</b>
<b>Serial Port [Enabled]</b> .....	<b>74</b>
<b>Change Settings [Auto]</b> .....	<b>74</b>
<b>Serial Port [Enabled]</b> .....	<b>75</b>
<b>Change Settings [Auto]</b> .....	<b>75</b>
<b>Serial Port [Enabled]</b> .....	<b>76</b>
<b>Change Settings [Auto]</b> .....	<b>76</b>
<b>Duplex Function [Full Duplex]</b> .....	<b>77</b>
<b>Parallel Port [Enabled]</b> .....	<b>78</b>
<b>Change Settings [Auto]</b> .....	<b>78</b>
<b>Device Mode [STD Printer Mode]</b> .....	<b>79</b>
<b>PC Health Status</b> .....	<b>80</b>
<b>CPU_FAN1 Smart Fan Control/SYS_FAN1 Smart Fan Control [Auto Mode]</b> .....	<b>81</b>
<b>Auto mode fan start/off temperature</b> .....	<b>81</b>
<b>Auto mode fan start PWM</b> .....	<b>82</b>
<b>Auto mode fan slope PWM</b> .....	<b>82</b>
<b>Wake system with Fixed Time [Disabled]</b> .....	<b>82</b>
<b>Console Redirection [Disabled]</b> .....	<b>84</b>
<b>Terminal Type [ANSI]</b> .....	<b>84</b>
<b>Bits per second [115200]</b> .....	<b>84</b>
<b>Data Bits [8]</b> .....	<b>84</b>
<b>Parity [None]</b> .....	<b>85</b>

Stop Bits [1].....	85
Auto Recovery Function [Disabled].....	86
Intel Virtualization Technology [Disabled] .....	87
EIST [Enabled].....	87
Serial-ATA (SATA) [Enabled].....	88
SATA Mode [IDE Mode].....	88
Security Device Support [Disabled].....	89
USB Devices.....	90
Legacy USB Support [Enabled].....	90
Primary Display [Auto] .....	93
DVMT Pre-Allocated [256M] .....	93
DVMT Total Gfx Mem [Max].....	93
Primary IGFX Boot Display [VBIOS Default] .....	93
Restore on AC Power Loss [Last State].....	94
Audio Controller [Enabled] .....	94
XHCI Mode [Smart Auto] .....	95
Speed [Auto].....	96
Administrator Password .....	96
User Password .....	96
Bootup NumLock State [On].....	97
Quiet Boot [Enabled] .....	98
UEFI Boot [Disabled] .....	98
Launch PXE OpROM [Disabled].....	98
Option ROM Messages [Force BIOS].....	98
Save Changes and Reset .....	99
Discard Changes and Reset .....	99
Restore Defaults .....	99
Save as User Defaults .....	99
Restore User Defaults .....	99



Appendix

**D**

# Terminology

---

<b>AC '97</b>	Audio Codec 97 (AC'97) refers to a codec standard developed by Intel® in 1997.
<b>ACPI</b>	Advanced Configuration and Power Interface (ACPI) is an OS-directed configuration, power management, and thermal management interface.
<b>AHCI</b>	Advanced Host Controller Interface (AHCI) is a SATA Host controller register-level interface.
<b>ATA</b>	The Advanced Technology Attachment (ATA) interface connects storage devices including hard disks and CD-ROM drives to a computer.
<b>ARMD</b>	An ATAPI Removable Media Device (ARMD) is any ATAPI device that supports removable media, besides CD and DVD drives.
<b>ASKIR</b>	Amplitude Shift Keyed Infrared (ASKIR) is a form of modulation that represents a digital signal by varying the amplitude (“volume”) of the signal. A low amplitude signal represents a binary 0, while a high amplitude signal represents a binary 1.
<b>BIOS</b>	The Basic Input/Output System (BIOS) is firmware that is first run when the computer is turned on and can be configured by the end user
<b>CODEC</b>	The Compressor-Decompressor (CODEC) encodes and decodes digital audio data on the system.
<b>CMOS</b>	Complimentary metal-oxide-conductor is an integrated circuit used in chips like static RAM and microprocessors.
<b>COM</b>	COM refers to serial ports. Serial ports offer serial communication to expansion devices. The serial port on a personal computer is usually a male DB-9 connector.
<b>DAC</b>	The Digital-to-Analog Converter (DAC) converts digital signals to analog signals.
<b>DDR</b>	Double Data Rate refers to a data bus transferring data on both the rising and falling edges of the clock signal.
<b>DMA</b>	Direct Memory Access (DMA) enables some peripheral devices to bypass the system processor and communicate directly with the system memory.

## PCISA-BT CPU Card

<b>DIMM</b>	Dual Inline Memory Modules are a type of RAM that offer a 64-bit data bus and have separate electrical contacts on each side of the module.
<b>DIO</b>	The digital inputs and digital outputs are general control signals that control the on/off circuit of external devices or TTL devices. Data can be read or written to the selected address to enable the DIO functions.
<b>EHCI</b>	The Enhanced Host Controller Interface (EHCI) specification is a register-level interface description for USB 2.0 Host Controllers.
<b>EIDE</b>	Enhanced IDE (EIDE) is a newer IDE interface standard that has data transfer rates between 4.0 MBps and 16.6 MBps.
<b>EIST</b>	Enhanced Intel® SpeedStep Technology (EIST) allows users to modify the power consumption levels and processor performance through application software. The application software changes the bus-to-core frequency ratio and the processor core voltage.
<b>FSB</b>	The Front Side Bus (FSB) is the bi-directional communication channel between the processor and the Northbridge chipset.
<b>GbE</b>	Gigabit Ethernet (GbE) is an Ethernet version that transfers data at 1.0 Gbps and complies with the IEEE 802.3-2005 standard.
<b>GPIO</b>	General purpose input
<b>HDD</b>	Hard disk drive (HDD) is a type of magnetic, non-volatile computer storage device that stores digitally encoded data.
<b>ICH</b>	The Input/Output Control Hub (ICH) is an Intel® Southbridge chipset.
<b>IrDA</b>	Infrared Data Association (IrDA) specify infrared data transmission protocols used to enable electronic devices to wirelessly communicate with each other.
<b>L1 Cache</b>	The Level 1 Cache (L1 Cache) is a small memory cache built into the system processor.
<b>L2 Cache</b>	The Level 2 Cache (L2 Cache) is an external processor memory cache.
<b>LCD</b>	Liquid crystal display (LCD) is a flat, low-power display device that consists of two polarizing plates with a liquid crystal panel in between.

<b>LVDS</b>	Low-voltage differential signaling (LVDS) is a dual-wire, high-speed differential electrical signaling system commonly used to connect LCD displays to a computer.
<b>POST</b>	The Power-on Self Test (POST) is the pre-boot actions the system performs when the system is turned-on.
<b>RAM</b>	Random Access Memory (RAM) is volatile memory that loses data when power is lost. RAM has very fast data transfer rates compared to other storage like hard drives.
<b>SATA</b>	Serial ATA (SATA) is a serial communications bus designed for data transfers between storage devices and the computer chipsets. The SATA bus has transfer speeds up to 1.5 Gbps and the SATA II bus has data transfer speeds of up to 3.0 Gbps.
<b>S.M.A.R.T</b>	Self Monitoring Analysis and Reporting Technology (S.M.A.R.T) refers to automatic status checking technology implemented on hard disk drives.
<b>UART</b>	Universal Asynchronous Receiver-transmitter (UART) is responsible for asynchronous communications on the system and manages the system's serial communication (COM) ports.
<b>UHCI</b>	The Universal Host Controller Interface (UHCI) specification is a register-level interface description for USB 1.1 Host Controllers.
<b>USB</b>	The Universal Serial Bus (USB) is an external bus standard for interfacing devices. USB 1.1 supports 12Mbps data transfer rates and USB 2.0 supports 480Mbps data transfer rates.
<b>VGA</b>	The Video Graphics Array (VGA) is a graphics display system developed by IBM.

Appendix

**E**

# Digital I/O Interface

---



## E.1 Introduction

The DIO connector on the PCISA-BT is interfaced to GPIO ports on the Super I/O chipset. The digital inputs and digital outputs are generally control signals that control the on/off circuit of external devices or TTL devices. Data can be read or written to the selected address to enable the DIO functions.



### NOTE:

For further information, please refer to the datasheet for the Super I/O chipset.

---

The BIOS interrupt call **INT 15H** controls the digital I/O.

### INT 15H:

<b>AH – 6FH</b>	
<u>Sub-function:</u>	
<b>AL – 8</b>	: Set the digital port as INPUT
<b>AL</b>	: Digital I/O input value

## PCISA-BT CPU Card

### E.2 Assembly Language Sample 1

```

MOV     AX, 6F08H      ;setting the digital port as input
INT     15H           ;

```

AL low byte = value

AH – 6FH
<u>Sub-function:</u>
AL – 9 : Set the digital port as OUTPUT
BL : Digital I/O input value

### E.3 Assembly Language Sample 2

```

MOV     AX, 6F09H      ;setting the digital port as output
MOV     BL, 09H        ;digital value is 09H
INT     15H           ;

```

Digital Output is 1001b

Appendix

**F**

# Watchdog Timer

---



**NOTE:**

The following discussion applies to DOS environment. Contact IEI support or visit the IEI website for specific drivers for other operating systems.

The Watchdog Timer is provided to ensure that standalone systems can always recover from catastrophic conditions that cause the CPU to crash. This condition may have occurred by external EMIs or a software bug. When the CPU stops working correctly, Watchdog Timer either performs a hardware reset (cold boot) or a Non-Maskable Interrupt (NMI) to bring the system back to a known state.

A BIOS function call (INT 15H) is used to control the Watchdog Timer.

INT 15H:

<b>AH – 6FH Sub-function:</b>	
AL – 2:	Sets the Watchdog Timer’s period.
BL:	Time-out value (Its unit-second is dependent on the item “Watchdog Timer unit select” in CMOS setup).

**Table F-1: AH-6FH Sub-function**

Call sub-function 2 to set the time-out period of Watchdog Timer first. If the time-out value is not zero, the Watchdog Timer starts counting down. When the timer value reaches zero, the system resets. To ensure that this reset condition does not occur, calling sub-function 2 must periodically refresh the Watchdog Timer. However, the watchdog timer is disabled if the time-out value is set to zero.

A tolerance of at least 10% must be maintained to avoid unknown routines within the operating system (DOS), such as disk I/O that can be very time-consuming.

**NOTE:**

When exiting a program it is necessary to disable the Watchdog Timer, otherwise the system resets.

**EXAMPLE PROGRAM:**

```
; INITIAL TIMER PERIOD COUNTER
```

```
;
```

```
W_LOOP:
```

```
;
```

```
    MOV     AX, 6F02H      ;setting the time-out value  
    MOV     BL, 30         ;time-out value is 48 seconds  
    INT     15H
```

```
;
```

```
; ADD THE APPLICATION PROGRAM HERE
```

```
;
```

```
    CMP     EXIT_AP, 1     ;is the application over?  
    JNE     W_LOOP        ;No, restart the application
```

```
    MOV     AX, 6F02H      ;disable Watchdog Timer  
    MOV     BL, 0         ;  
    INT     15H
```

```
;
```

```
; EXIT ;
```



Appendix

G

# Hazardous Materials Disclosure

---

The details provided in this appendix are to ensure that the product is compliant with the Peoples Republic of China (China) RoHS standards. The table below acknowledges the presences of small quantities of certain materials in the product, and is applicable to China RoHS only.

A label will be placed on each product to indicate the estimated “Environmentally Friendly Use Period” (EFUP). This is an estimate of the number of years that these substances would “not leak out or undergo abrupt change.” This product may contain replaceable sub-assemblies/components which have a shorter EFUP such as batteries and lamps. These components will be separately marked.

Please refer to below table.

Part Name	Toxic or Hazardous Substances and Elements					
	Lead (Pb)	Mercury (Hg)	Cadmium (Cd)	Hexavalent Chromium (CR(VI))	Polybrominated Biphenyls (PBB)	Polybrominated Diphenyl Ethers (PBDE)
Housing	O	O	O	O	O	O
Display	O	O	O	O	O	O
Printed Circuit Board	O	O	O	O	O	O
Metal Fasteners	O	O	O	O	O	O
Cable Assembly	O	O	O	O	O	O
Fan Assembly	O	O	O	O	O	O
Power Supply Assemblies	O	O	O	O	O	O
Battery	O	O	O	O	O	O
<p>O: This toxic or hazardous substance is contained in all of the homogeneous materials for the part is below the limit requirement in SJ/T11363-2006 (now replaced by GB/T 26572-2011).</p> <p>X: This toxic or hazardous substance is contained in at least one of the homogeneous materials for this part is above the limit requirement in SJ/T11363-2006 (now replaced by GB/T 26572-2011).</p>						

## PCISA-BT CPU Card

此附件旨在确保本产品符合中国 RoHS 标准。以下表格标示此产品中某有毒物质的含量符合中国 RoHS 标准规定的限量要求。

本产品上会附有“环境友好使用期限”的标签，此期限是估算这些物质“不会有泄漏或突变”的年限。本产品可能包含有较短的环境友好使用期限的可替换元件，像是电池或灯管，这些元件将会单独标示出来。

部件名称	有毒有害物质或元素					
	铅 (Pb)	汞 (Hg)	镉 (Cd)	六价铬 (CR(VI))	多溴联苯 (PBB)	多溴二苯 醚 (PBDE)
壳体	○	○	○	○	○	○
显示	○	○	○	○	○	○
印刷电路板	○	○	○	○	○	○
金属螺帽	○	○	○	○	○	○
电缆组装	○	○	○	○	○	○
风扇组装	○	○	○	○	○	○
电力供应组装	○	○	○	○	○	○
电池	○	○	○	○	○	○

○: 表示该有毒有害物质在该部件所有物质材料中的含量均在 SJ/T11363-2006 (现由 GB/T 26572-2011 取代) 标准规定的限量要求以下。

X: 表示该有毒有害物质至少在该部件的某一均质材料中的含量超出 SJ/T11363-2006 (现由 GB/T 26572-2011 取代) 标准规定的限量要求。