

Datasheet

SATA Slim 3MG2-P series

- SATA III solution for industrial field
- High IOPS solution
- iData Guard protection
- iSMART disk health monitoring
- Intelligent error recovery system
- Excellent data transfer speed
- Zero mechanical interference
- Compatible with JEDEC MO-297 standard

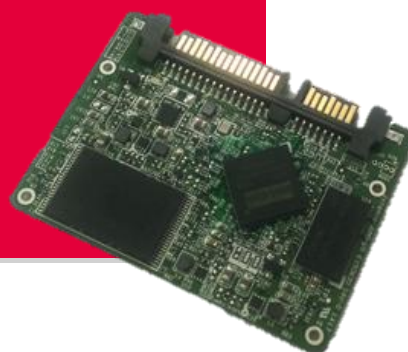

Introduction

Innodisk SATA Slim 3MG2-P is SATA III 6Gb/s Flash based disk, which designed with standard SATA interface (7+15 SATA connector), and compatible with JEDEC MO-297 standard. With its smaller dimension, SATA Slim 3MG2-P is an alternative solution of 2.5" SSD for those embedded system that may have mechanical and space concerns. Innodisk SATA Slim 3MG2-P operates under SATA III (6.0Gb/s) interface with excellent performance and reliability making it the ideal solution for a variety of applications, including embedded system, and industrial field.

SATA Slim 3MG2-P series Drawing

Contact us for more information
about the SATA Slim 3MG2-P

Innodisk is a service-driven provider of industrial embedded flash and DRAM storage products and technologies, with a focus on the industrial/embedded, aerospace and defense, and cloud computing industries.

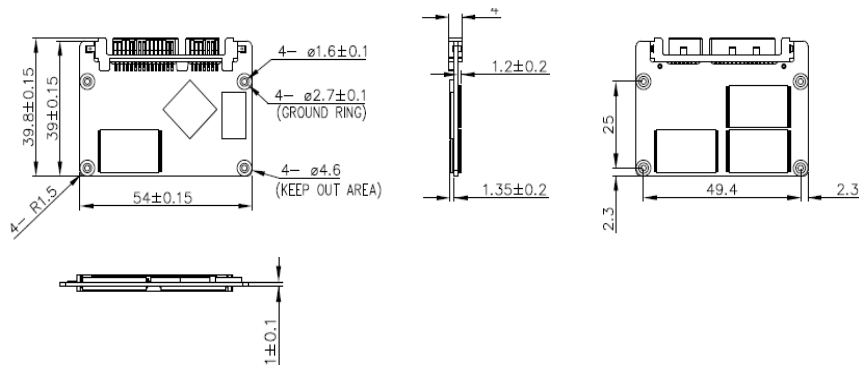

Interface	SATA III
Flash Type	MLC
Capacity	8GB~128GB
Max. Channels	4
Sequential R/W (MB/sec, max.)*	520/165 MB/s
4KB Random (QD32) R/W (IOPS)**	70,000/13,000
Max. Power Consumption	2.6W (5V x 520 mA)
Thermal Sensor	√
External DRAM Buffer	√
H/W Write Protect	Optional
Pin7 Power	-
ATA Security	√
S.M.A.R.T.	√
DEVSLP Mode	√ (min. power consumption 3mW)
Slumber Mode	√ (min. power consumption 30mW)
Dimension (WxLxH)	54.0 X 39.0 X 4.0 mm
Environment	Vibration: 20G @7~2000Hz Shock: 1500G @ 0.5ms Storage Temperature: -55°C ~ +95°C MTBF: 3 million hours
* Sequential performance based on CystalDiskMark 3.01 with file size 1000MB	
** Random performance based on Iometer with Queue Depth 32	

Headquarters (Taiwan)

5F., No.237, Sec. 1, Datong Rd.,
Xizhi Dist., New Taipei City 221,
Taiwan (R.O.C.)

Tel: +886-2-77033000
Email: sales@innodisk.com

Branch Offices:

USA
usasales@innodisk.com
+1-510-770-9421

Europe
eusales@innodisk.com
+31-040-282-1818

Japan
jpsales@innodisk.com
+81-45-6594-7581

China
sales_cn@innodisk.com
+86-755-21673689
www.innodisk.com

© 2014 Innodisk Corporation.
All right reserved. Specifications
are subject to change without
prior notice.

Ordering Information

Operation Temp.	8GB	16GB	32GB	64GB	128GB
Standard Grade (0°C ~ +70°C)	DGSLM-08GD81SC1SC	DGSLM-16GD81SC1DC	DGSLM-32GD81SC1QC	DGSLM-64GD81SC1QC	DGSLM-A28D81SC1QC
Industrial Grade (-40°C ~ +85°C)	DGSLM-08GD81SW1SC	DGSLM-16GD81SW1DC	DGSLM-32GD81SW1QC	DGSLM-64GD81SW1QC	DGSLM-A28D81SW1QC

innodisk

www.innodisk.com